

MODERN
COMPRESSED AIR
LOCOMOTIVES



ENERGY FROM ATMOSPHERIC HEAT

H · K · PORTER COMPANY
PITTSBURGH · PENNSYLVANIA
· U · S · A ·

M Johnston Collection
scanned 2006
missing pages 31-40, 49-54

757

MODERN
Compressed Air
LOCOMOTIVES

A DESCRIPTIVE CATALOGUE OF TWO-STAGE
COMPRESSED AIR LOCOMOTIVES AND THE
NECESSARY AUXILIARY APPARATUS FOR
SUCCESSFUL OPERATION AND MAINTENANCE

SECOND EDITION
COPYRIGHT 1914

H. K. PORTER COMPANY
PITTSBURGH, PENNSYLVANIA, U.S.A.

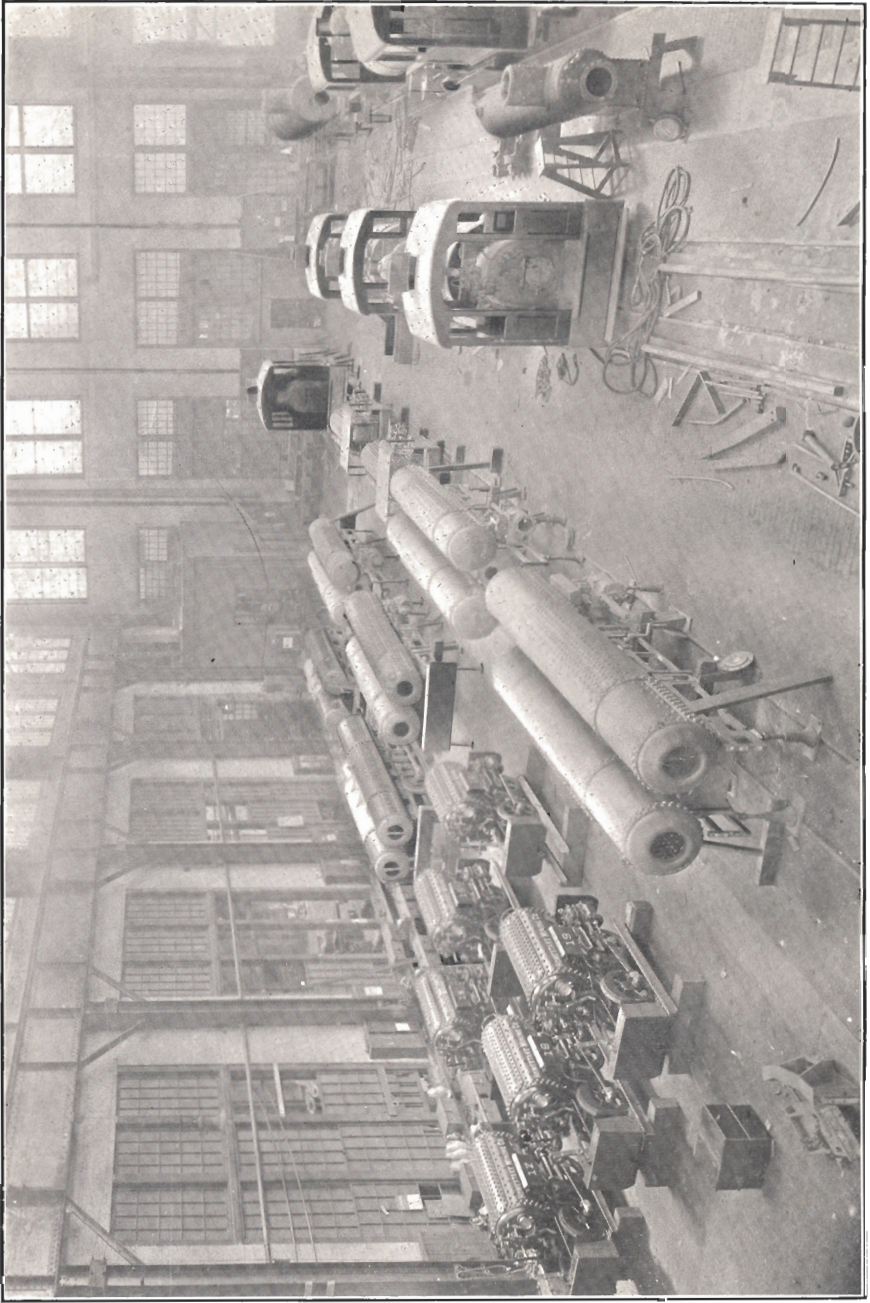

A corner of the erecting floor with compressed air locomotives under construction: six 18-inch gauge for copper mine; two 42-inch gauge for anthracite coal mine; six 44-inch gauge for main entry haulage; in bituminous coal mine.

H. K. PORTER COMPANY

OFFICE: UNION BANK BUILDING

WORKS: 49TH STREET AND ALLEGHENY

VALLEY DIVISION OF PENNSYLVANIA R. R.

PITTSBURGH, PENNSYLVANIA

Builders of

LOCOMOTIVES

LIGHT AND HEAVY—STEAM AND COMPRESSED AIR

Manufacturers of

REDUCING AND STOP VALVES, CHARGING STATIONS, STORAGE TANKS, PIPE FLANGES, ELBOWS AND TEES, ETC., FOR USE IN CONNECTION WITH COMPRESSED AIR LOCOMOTIVES

Designers of and Contractors for

COMPLETE COMPRESSED AIR HAULAGE PLANTS INCLUSIVE OF LOCOMOTIVES, COMPRESSORS, PIPE LINES, STORAGE TANKS, CHARGING STATIONS AND ALL NECESSARY FITTINGS AND VALVES

LOCOMOTIVES ILLUSTRATED AND DESCRIBED IN THIS CATALOGUE ARE FULLY COVERED BY LETTERS PATENT

HISTORICAL SKETCH

The history of the compressed air locomotive may be divided into three periods:

The first, from 1873 to 1895. During this time no one gave any particular attention to this type of locomotive and the few that were built—about ten in twelve years—were built to meet an occasional customer's views, without consecutive effort on the part of the builder to improve his product.

The second, from 1895 to 1908. In 1895 the H. K. Porter Company decided to devote time and money to their systematic development. As a result the details of construction were greatly improved and the air locomotive became generally recognized as a safe and convenient motive power for gaseous coal mines and in other localities where fire, sparks, heat or the products of combustion were particularly objectionable. During this period of thirteen years about three hundred single-expansion compressed air locomotives were built.

The third period began with the delivery of the first two-stage compressed air locomotive to the Susquehanna Coal Company, in 1908. This locomotive was the result of a long series of experiments conducted by the H. K. Porter Company to develop this machine. As a result of this careful preparatory work, which began in 1904, the first two-stage locomotive was an immediate success. Before any comparative tests were made the daily operation of this locomotive in charge of a man who had been operating single-expansion compressed air locomotives under similar conditions demonstrated that the two-stage locomotive was no more difficult to control or take care of, and that doing the same quantity of work it required to be charged much less frequently.

Comparative tests made later showed a gain in efficiency of over 50 per cent., and a saving in compressed air consumed of over 30 per cent. These tests were made under actual working conditions, and in a manner equally convincing to the theoretical engineer and to the practical business man. The same trains were hauled the same distances over the same piece of track, with the same man operating alternately a two-stage and a single-expansion locomotive of the same tank capacity, weight and tractive force. The average of the results of all such trials showed a gain in efficiency and a resultant saving in the power required to furnish the necessary supply of air slightly better than the figures above mentioned.

As a natural result this locomotive attracted considerable attention, and others of the same type were purchased for the mines of the Susquehanna Coal Company, and other adjoining properties.

THE TWO-STAGE COMPRESSED AIR LOCOMOTIVE

It is a locomotive in which compressed air is partially expanded in a high-pressure cylinder until it becomes much colder than the surrounding atmosphere. This air is then passed through an interheater in which it is heated to nearly atmospheric temperature by extended contact with the surrounding air. The expansion is then completed in a low-pressure cylinder.

If air could be compressed without heating and expanded without cooling nearly all of the losses which occur in transmitting power by means of compressed air would be eliminated. It is obvious that in the cylinders of a locomotive the air is not in sufficiently extended contact with the warmer containing walls of the cylinder to prevent refrigeration to any considerable degree.

The two-stage locomotive has therefore been designed to expand the air in two successive cylinders with an atmospheric interheater located between them, through which the exhaust air from the high-pressure cylinder passes before it enters the low-pressure cylinder.

The construction of the interheater in its most efficient form is clearly shown by the diagram on page 68. It consists of a cylindrical steel casing filled with aluminum or brass tubes of small diameter, around and between which, guided by the baffle plates, the air passes. The final exhaust air from the low-pressure cylinder is utilized in an ejector apparatus, similar to the smoke stack and exhaust nozzle of a steam locomotive, to draw a rapid current of the surrounding atmospheric air through the small tubes.

Thus the exhaust from the high-pressure cylinder, the temperature of which has dropped to about 140° Fahrenheit below that of the atmosphere, due to its expansion and the work done in the high-pressure cylinder, is brought into close contact with large quantities of atmospheric air for a sufficient length of time to raise the temperature of this exhaust air to within a few degrees of that of the atmosphere.

The ordinary pressure of the air entering the high-pressure cylinder is 250 pounds per square inch, and the corresponding pressure entering the low-pressure cylinder is 50 pounds. Approximately equal quantities of work are done between 250 pounds pressure and 50 pounds, and between 50 pounds and atmospheric pressure.

If compressed air could be expanded in a single cylinder without refrigeration, air at 50 pounds pressure would do $^{613}_{1000}$ as much work

THE TWO-STAGE COMPRESSED AIR LOCOMOTIVE

as air at 150 pounds. Practically on account of increased refrigeration and the limitations of the valve gear, air at 50 pounds pressure does $\frac{75}{100}$ as much work in a locomotive cylinder as air at 150 pounds pressure. In the high-pressure cylinder of the two-stage locomotive the same quantity of work is done, but the heat lost is restored in the atmospheric interheater, so that with only 75 per cent. of the degree of refrigeration that occurs in the usual type of single-expansion air locomotive, 50 per cent. more work is actually obtained from the same quantity of compressed air.

The two-stage compressed air locomotives described more fully in the later pages of this book are based on sound theory worked out in a practical way to show under actual every-day conditions the results as compared with a single-expansion locomotive indicated above.

From time to time efforts have been made to increase the efficiency of the compressed air locomotive by use of more elaborate valve gears and by the use of compound cylinders; but without effective and substantial preheating or interheating, all such efforts were predestined to failure.

done without otherwise unnecessary movements of the locomotive and without unavoidable stops. If these matters are given proper consideration the time required for charging is unimportant, as the locomotive can come to rest, receive a charge of air and be in motion again inside of one minute and a half.

Stationary Storage is usually required in order that the locomotive may be charged promptly and the compressors run continuously. The locomotive is usually charged to a pressure of about 800 pounds per square inch. The volume and pressure in the stationary storage should be such that a sufficient quantity of air can be drawn from it to charge the locomotive without reducing the pressure below that to which the locomotive is to be charged.

In designing stationary storage for a plant which requires charging stations any considerable distance apart or away from the compressor, it is usually best and most economical to use pipe of sufficient size to give the required volume, as a combination of storage tanks and pipe of smaller diameter is nearly always more expensive.

Compressors supplying locomotives with air must deliver the air at a relatively high pressure—much higher than the pressure at which the air is admitted to the cylinders of the locomotive, in order that a sufficient quantity may be available to drive the locomotive a distance on one charge, which when everything is considered, will give the best and most economical results. Ordinarily a compressor capable of compressing air to a pressure of about 1000 pounds per square inch is found most satisfactory.

Pressures below 200 pounds are absolutely impracticable and 200 pounds is only satisfactory for very light loads, easy grades and distances of a few hundred feet. For this reason it is usually impracticable to utilize air from the same pipe line for locomotives and other general purposes which do not require high pressures.

The required pressure is determined by the work which the locomotive should perform on one charge of air, considered in connection with the limiting dimensions of the locomotive which govern the dimensions of the main reservoir. The lower the pressure the larger the main reservoir must be to contain a given quantity of air for use in the locomotive cylinders. Experience has shown that it is usually desirable to have the locomotive perform as much work as possible on one charge without exceeding limitations in regard to weight, length, width and height. These considerations ordinarily fix the desirable pressure in the locomotive main reservoir at 700 to 900 pounds and in the stationary storage at 900 to 1200 pounds.

THE FIELD OF THE COMPRESSED AIR LOCOMOTIVE

A compressor, pipe line and charging stations, in addition to the locomotives, usually make the first cost of an installation of compressed air locomotives from two to three times as great as for steam locomotives, and a little more or a little less than an installation of electric locomotives, generators, trolley wires, bonded rails, etc., of the same capacity.

Compared with steam locomotives, one or more of the following features must be of sufficient value to justify the additional expenditure:

1. Absolute insurance against fire or an explosion due to sparks, flame or heat emitted or caused by the locomotive.
2. Cleanliness. The locomotive exhausts nothing but pure air and cannot contaminate the atmosphere, blacken the walls or ceiling, or soil fabrics or raw material in cotton, woolen or paper mills.
3. Power generated **how, where** and, to a limited extent, **when** it is most convenient and economical.

How. From sawdust, refuse or poor coal; from waste heat at steel plants, copper reduction works or coke ovens; or by electricity or water power.

Where. Compressed air at 1000 pounds pressure can be conveyed indefinite distances through 3-inch pipe, or smaller, without appreciable loss and the cost of the plant is not greatly increased by the locomotive being charged a mile or more away from the compressor. Much longer distances are perfectly practicable, when the results to be obtained justify the expenditure.

When. With the locomotive and stationary storage charged, the locomotive can travel from two to ten miles with service loads without starting the compressor, and the tanks and pipe line will hold air for many hours without material loss, making it possible where the locomotive is not used continuously to run the compressor only during part of the day and the locomotive when required.

4. A locomotive which can stand a day or two absolutely without attention and go to work within less than a minute after the engineer steps into the cab.

5. A locomotive which in many cases will be found most economical when operating and *contingent* expenses, fixed charges and depreciation are all given correct relative values.

6. A locomotive which does not require a licensed engineer to run it.

As compared with electric locomotives, the advantages are that the air locomotives do not require trolley wires and bonded rails. Bonding rails is expensive, and naked trolley wires are dangerous and are often very much in the way. In wet mines the current runs off with the water and when the roof is bad the trolley wire is continually interrupting operation by getting knocked down.

In passing through switches the trolley pole takes the wrong wire, and every time the motion of the locomotive is reversed the trolley pole must be turned around or very carefully watched.

Trolley wires kill men by electric shock, cause fires and explosions by sparks and short circuit.

Contrary to the generally accepted opinion, the cost of power to operate compressed air locomotives is no greater than for electric locomotives, unless the load factor and operating conditions are unusually favorable to electrical operation.

The compressed air locomotive requires pipe lines and charging stations, but the locomotive can go from two to eight thousand feet away from the charging station and come back again, so the pipes and charging stations can be kept in the most convenient places. The saving in operating expenses, if any, depends upon local conditions, as does the value of eliminating the undesirable features connected with a trolley wire, so that in some cases compressed air is obviously indicated, and in others a careful analysis is required in order to decide wisely.

SOME PRACTICAL CONSIDERATIONS

Reliability. A haulage system that can be depended upon to work all day and every day, in the hands of workmen of ordinary ability, is a reliable system. Other qualities are desirable, but reliability is a necessity. In developing our system of haulage by compressed air locomotives we have kept the vital importance of this quality constantly in mind, and have never lost sight of it in our efforts to reduce the selling price and secure a high mechanical efficiency.

Compared with all other systems, the machinery of a compressed air haulage plant is simple, strong and accessible. Reasonably efficient inspection readily detects the necessity for adjustment or renewals, and prevents annoying delays or breakdowns.

Persons not practically familiar with air haulage frequently have the impression that serious difficulty is to be anticipated from freezing in the exhaust passages of the locomotive. Compressed air locomotives have been used for thirty years, and no such difficulty has developed. This difficulty is suggested by the freezing which sometimes occurs when air is used at lower pressures. With the higher pressures used in con-

nection with locomotives this difficulty is eliminated, as practically all of the moisture is squeezed out of the air in the process of compression and deposited in the stationary storage, or in the tanks of the locomotive, where it can be drawn off at convenient times. The outside of the locomotive cylinders and valve chests is frequently coated with frost, and the exhaust produces a light mist by condensing atmospheric moisture; but there is nothing in the working parts of a compressed air locomotive, if a suitable oil is used, which is frozen.

Adequacy. Compressed air locomotives meet the exacting requirements of many industrial and mining transportation problems more satisfactorily than any other form of motive power. They are powerful, quick to start and stop, and easily controlled. They will stand abuse at the hands of unskilled operatives if given daily inspection by a machinist. The smaller sizes will operate over curves as sharp as 12 feet radius.

Underground they can be operated satisfactorily in wet mines where a dripping roof and sloppy floor would render any other type of locomotive excessively troublesome. In mines with bad roof, where the trolley wires are so frequently knocked down or injured by slight falls, the compressed air locomotive is found most satisfactory, as the locomotive can travel two or three thousand feet away from the pipe line and return, and the pipe line itself can be located in the safest places. The air locomotive can go into every room and cross entry without wiring the entry and bonding the rails or using a cable that drags on the ground, wears out and causes expense.

On the surface, within a radius of two or three miles, compressed air locomotives are the equivalent in power and flexibility of a steam locomotive of the same weight, and will do exactly the same work without fire, smoke, heat, dirt or sparks.

REPAIR ACCOUNT AND OPERATING EXPENSES

The repair account of a compressed air locomotive is comparable to that of a steam locomotive with all expenses for boiler repairs left out, as the tanks composing the main reservoir never require repairs. This, combined with the less expensive men required to run them, is frequently a sufficient reason for the adoption of compressed air locomotives where a number are to be operated from one central power station. A comparison of the cost of repairs for compressed air locomotives and electric locomotives is decidedly in favor of the air. As compared with rope haulage it is nearly always less, but the life of rope and sheaves is so dependent upon the straightness of the haul and upon the atmospheric and other conditions that any general comparison is impossible.

The cost of operatives (locomotive runners and trainmen) for compressed air locomotives is as low as it is for any other system. It is a mistake to trust good machinery of any sort to ignorant or careless men, but high-priced labor is unnecessary in connection with air locomotives. Experience has shown that where mules are replaced by air locomotives it does not take long for a good mule driver to become a good compressed air locomotive runner.

The compressor is equipped with speed and pressure governors and runs at moderate speeds, so that the man in charge can easily attend to other duties in the same or adjacent buildings. It is not subjected to the sudden variations of load so troublesome in connection with the operation of generators for electric haulage, as the locomotives, when in operation, are independent of the compressor, and there may be one or twenty charged by one compressor, and yet by virtue of their independent action after charging all can be starting heavy trains at the same instant without in any way affecting the continuous operation of the plant.

SAFETY

Large sums are expended yearly for fire and other insurance, but insurance does not prevent fires and other losses. It is money paid to secure partial indemnity for any loss which may occur.

Money expended judiciously for appliances, methods and materials which reduce the risk to a minimum is the best kind of insurance, for they prevent accidents and reduce insurance rates.

The greatest loss of human life in mine explosions is due, not so much to the direct effects of the explosion, whether of gas or of dust, as to the "after-damp." If the mine is equipped with air-haulage, the pipe line will supply fresh, pure air to those whose escape is cut off. If the mine is not equipped with air power, it may be impossible to save a single life. In case of fire, the air pipe line can be used to carry water.

Compressed air is a means of operating a locomotive which removes the danger due to sparks, flame, smoke, electric shock, short circuit and poisonous gases. *No other type of locomotive removes them all.*

In the United States Naval Magazines no other type of locomotive is employed.

In gaseous coal mines it is the only type of locomotive which meets the requirements of the State and National Bureaus of Mines.

With it there are no trolley wires, which have killed hundreds by electric shock and started thousands of fires by short circuits.

With it there is no hot, smoky, poisonous exhaust; nothing but pure, cold air. It has been possible for the compressor to supply air vitiated by incomplete combustion in the receivers, or pipe line, to the locomotive

THE TWO-STAGE COMPRESSED AIR LOCOMOTIVE

when the compressor was in bad order, and too much lubricating oil was used, but today, without gross negligence, this is impossible. A patented fusible plug near the discharge valves of the compressor warns the engineer in time for him to prevent the formation of objectionable gases.

It is a locomotive which can be used anywhere without additional risk to life or property:

In dusty and gaseous coal mines.

In mines with poor ventilation.

In wet mines.

In mines with bad roof.

In mines that are heavily timbered.

In lumber yards and warehouses.

Around plants for the manufacture of explosives and around cotton mills and compresses.

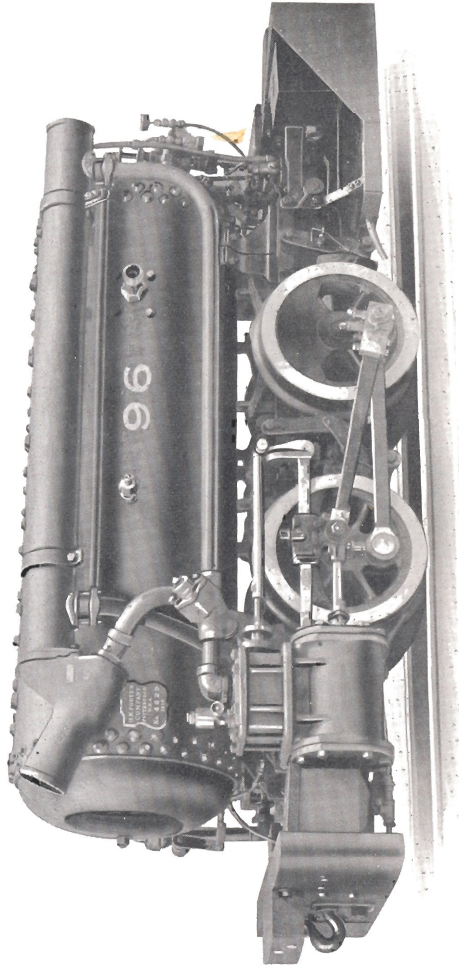

ILLUSTRATION No. 96, CLASS B-P-O

Four sizes, each with code word of the above design are described on the opposite page, and the principal dimensions, weight, power and other details are given in the column assigned to each size. We are prepared to build other sizes, and to construct these locomotives for any practicable gauge of track and size of entry. Bumpers and draft rigging are designed to suit the special requirements of the customer. A light canopy to protect the engineer, and headlights will be furnished if required. The smaller sizes are especially adapted for extremely narrow gauges, usually in gold silver and copper mines. The dimensions of the locomotive, the pressure and capacity of the tank are in every case adjusted to the requirements and conditions. These locomotives run quietly and steadily, pass sharp curves easily and surmount as steep grades as are practicable for any locomotive on ordinary rail. Two inches clearance between the highest point of the locomotive and the lowest in the entry is abundant, as the height of the locomotive cannot increase, but decreases a trifle by the wear of the tires and journal brasses.

CODE WORD	PEBLOW	PEBMUX	PEBNAZ	PEBREC
Cylinders { Diameter (inches), High Pressure Stroke (inches), Low Pressure	4½ 9 10 22 2-9	5½ 11 10 23 2-9	6 12 12 24 3-0 or 4-0 12 to 15-6	7 14 14 26 4-0 12 to 18-6
Diameter of driving wheels (inches)	9 to 12-6	10 to 12-6	13	14
Rigid wheel base (feet and inches)	11	12¾	15	16½
Length over bumpers (feet and inches)	12¾	14¾		
*Extreme width outside gauge at cylinders (inches) { H.P. L.P.				
Height (see note)	20 to 60	30 to 75	60 to 104	60 to 120
Main reservoir capacity (cubic feet)	6 to 9	7 to 11	9 to 12-6	9 to 15
Main reservoir length (feet and inches)	24 to 36	36 to 40	36 to 40	36 to 40
Main reservoir diameter (inches)	700 to 1200	700 to 1200	700 to 1200	700 to 1200
Main reservoir charging pressure (pounds per square inch)	250	250	250	250
Auxiliary reservoir pressure (pounds per square inch)				
Weight in working order (pounds)	7000 to 10000	10000 to 13000	14000 to 17000	18000 to 22000
Tractive force (pounds)	1450	2200	3000	4400
‡Hauling capacity—in tons of 2000 pounds (exclusive of locomotive) 20 pounds per ton rolling friction.				
On absolute level	68	104	142	210
On 1 per cent. grade	32	49	67	100
On 2 per cent. grade	19	30	42	63
On 3 per cent. grade	13	21	29	45
On 5 per cent. grade	7	12	17	26
Weight per yard of lightest rail advised (pounds)	16	16	20	30
Radius of sharpest curve advised (feet)	15	15	20	30
Radius of sharpest curve practicable (feet)	12	12	15	20

*Width outside of gauge line may be reduced by special construction.

‡The hauling capacities tabulated above are the maximum for the conditions stated. For satisfactory operation the train weights should be from 50 to 90 per cent. of the above figures.

NOTE.—The minimum height of this type of locomotive is dependent upon the gauge of track; the narrow gauges requiring more height than the wider ones. Full information furnished on request for any size of locomotive or main reservoir capacity.

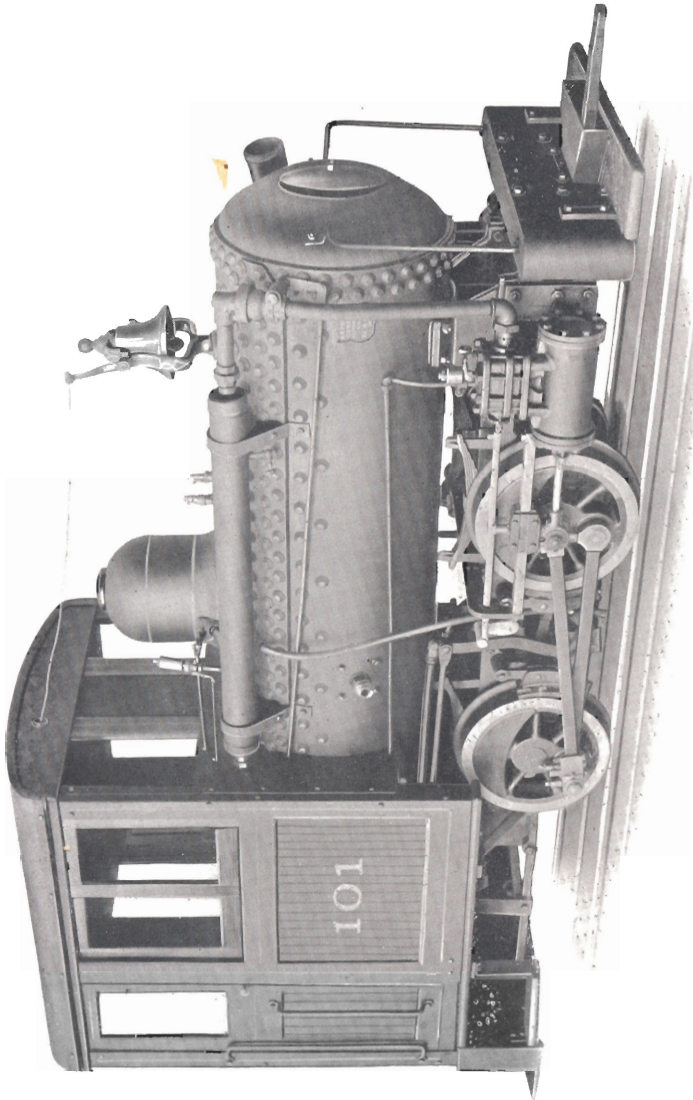

ILLUSTRATION No. 101, CLASS B-P

Four sizes, each with code word, of the above design are described on the opposite page, and the principal dimensions, weight, power and other details are given in the column assigned to each size. We are prepared to build other sizes, and to construct these locomotives for any practicable gauge of track or limits of head room or side room. The pressure, tank capacity and other details of construction are in every way adjusted to the head room and side room length of haul, grades, loads and other working conditions. These locomotives run steadily and quickly pass sharp curves and surmount as steep grades as are practicable for any locomotive on ordinary rail. Bumpers and draft rigging are designed to suit the special requirements of the purchaser.

CODE WORD	PEABAS	PEAGUS	PEADIS	PEAFOS
Cylinders { Diameter (inches), High Pressure Diameter (inches), Low Pressure Stroke (inches)	4 1/2	5 1/2	6	7
	9	11	12	14
Diameter of driving wheels (inches)	10	10	12	14
	22	23	24	26
Rigid wheel base (feet and inches)	2-9	2-9	3-0	4-0
Length over bumpers (feet and inches)	9 to 12-6	10 to 12-6	12 to 15-6	12-6 to 18-6
*Extreme width outside gauge at cylinders (inches) † I.P. (I.P.)	11	12 3/4	13	14
	12 1/4	14 1/4	15	16 1/2
Height above rail, head room not limited (feet and inches)	8-0	8-6	8-6	9-0
Main reservoir capacity (cubic feet)	20 to 60	30 to 75	60 to 104	60 to 120
Main reservoir length (feet and inches)	6 to 9	7 to 11	9 to 12-6	9 to 15
Main reservoir diameter (inches)	24 to 36	30 to 40	36 to 40	36 to 40
Main reservoir charging pressure (pounds per square inch)	700 to 1200	700 to 1200	700 to 1200	700 to 1200
Auxiliary reservoir pressure (pounds per square inch)	250	250	250	250
Weight in working order (pounds)	5000 to 10000	10000 to 13000, 14000 to 17000, 18000 to 22000	14000 to 17000, 18000 to 22000	18000 to 22000
Traction force (pounds)	1450	2200	3000	4400
‡Hauling capacity in tons of 2000 pounds (exclusive of locomotive), 20 pounds per ton rolling friction:				
On absolute level	68	104	142	210
On 1 per cent. grade	32	49	67	100
On 2 per cent. grade	19	30	42	63
On 3 per cent. grade	13	21	29	45
On 5 per cent. grade	7	12	17	26
Weight per yard of lightest rail advised (pounds)	16	16	25	30
Radius of sharpest curve advised (feet)	15	15	20	30
Radius of sharpest curve practicable (feet)	12	12	15	20

*This may be decreased in special cases.

†The hauling capacities tabulated above are a maximum for the conditions stated. For satisfactory operation the train weights should be from 50 to 90 per cent. of the above figures.

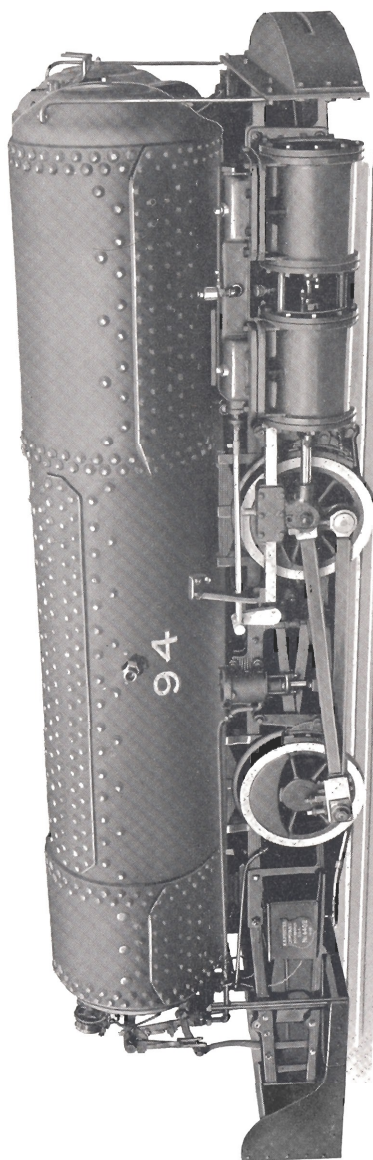

ILLUSTRATION No. 94, CLASS B-PP-O

Four sizes, each with code word, of the above design are described on the opposite page and the principal dimensions, weight, power and other details are given in the column assigned to each size. We are prepared to build other sizes and to construct these locomotives for any practicable gauge of track and size of entry. Bumpers and draft rigging are designed to suit the special requirements of the purchaser. A light canopy to protect the engineer, and headlights will be furnished if required. The dimensions of the locomotive, the pressure and the capacity of the tanks are in every case adjusted to the height and width of entry, length of haul, grades, loads and working conditions. These locomotives run steadily pass sharp curves easily and surmount as steep grades as are practicable for any locomotive on ordinary rail. Two inches clearance between the highest point of the locomotive and the lowest place in the entry is abundant as the height of the locomotive cannot increase, but will decrease a trifle by the wear of tires and journal brasses.

CODE WORD	PECRAB	PECSEC	PECTED	PECVOF
Cylinders (Diameter (inches), High Pressure { Diameter (inches), Low Pressure { Stroke (inches)	7 14 14 26 4-0	8½ 12 and 12 14 26 4-6	9½ 14 and 14 14 26 4-6	10 14 and 14 14 26 5-0
Rigid wheel base (feet and inches) Length over bumpers (feet)	14 to 20	16 to 20	18 to 21	20 to 23
*Extreme width outside gauge at cylinders (inches) { H.P. { L.P.	14 16½	15½ 16¾	16½ 17¾	17¾ 17¾
Extreme width across main reservoir tanks (feet and inches) *Height above rail (feet and inches)	5-5 to 6-5 5-0 to 5-10	5-5 to 6-5 5-0 to 5-10	5 10 to 6-10 5-0 to 5-10	5-10 to 6-10 5-5 to 5-10
Main reservoir, 2 tanks, capacity (cubic feet)	97 to 160	114 to 210	160 to 275	160 to 290
Main reservoir lengths (feet)	10 to 18	12 to 18	14 to 20	16 to 21
Main reservoir diameters (inches)	30 to 36	30 to 36	32½ to 38½	32½ to 38½
Main reservoir charging pressure (pounds per square inch) Auxiliary reservoir pressure (pounds per square inch)	700 to 1200 250	700 to 1200 250	700 to 1200 250	700 to 1200 250
Weight in working order (pounds) Tractive force (pounds)	20000 to 27000 4400	28000 to 36000 6400	32000 to 42000 8000	43000 to 46000 9000
†Hauling capacity—in tons of 2000 pounds (exclusive of locomotive), 20 pounds per ton rolling friction: On absolute level	206	305	380	437
On 1 per cent. grade	96	145	180	207
On 2 per cent. grade	59	92	113	130
On 3 per cent. grade	31	65	80	92
On 5 per cent. grade	22	38	46	53
Weight per yard of lightest rail advised (pounds) Radius of sharpest curve advised (feet) Radius of sharpest curve practicable (feet)	30 30 16	40 35 18	45 40 20	50 50 25

*This may be decreased in special cases.

†The hauling capacities tabulated above are a maximum for the conditions stated. For satisfactory operation the train weights should be from 50 to 90 per cent. of the above figures.

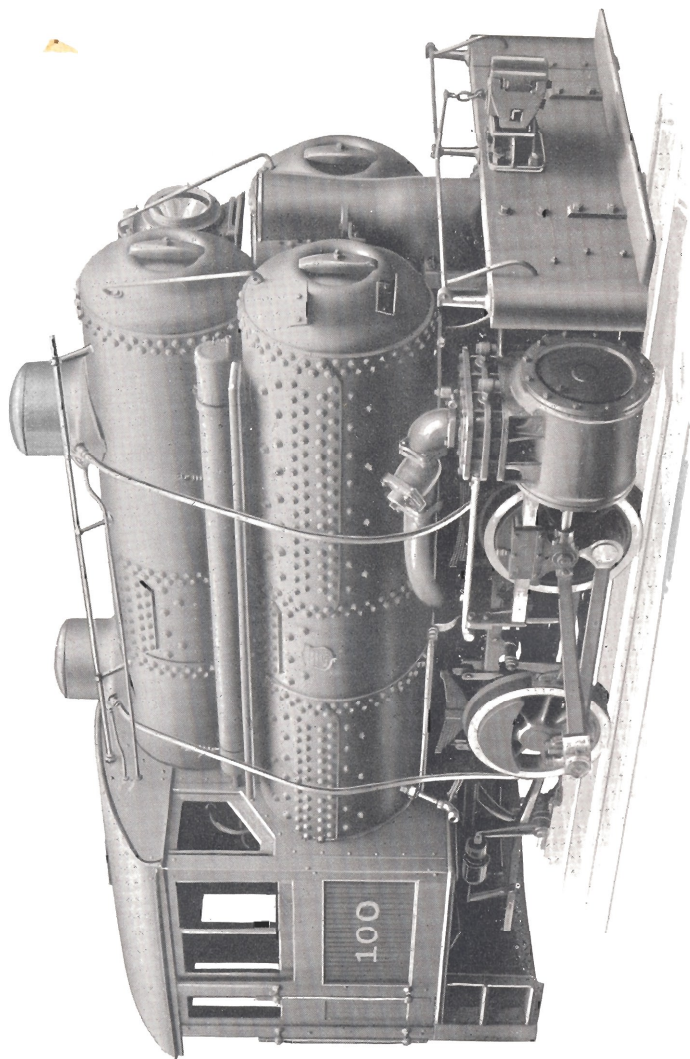

ILLUSTRATION No. 100, CLASS B-PPP AND B-PP

Five sizes, each with code word, of the above design, with two or three main reservoir tanks, are described on the opposite page, and the principal dimensions, weight power and other particulars are given in the column assigned to each size. We are prepared to build other sizes, and to construct these locomotives for any practicable gauge of track or limits of head room or side room. Bumpers and draft rigging are designed to suit the special requirements of the purchaser. Headlights will be furnished if required. The dimensions of the locomotive, the pressure and capacity of the tanks are in every case adjusted to the head room and side room, length of haul, grades, loads and other working conditions. These locomotives run steadily, pass sharp curves easily and surmount as steep grades as are practicable for any locomotive on ordinary rail.

CODE WORD	PEDSIF	PEDTOG	PEDVAH	PEDWIK	PEDYAM
Cylinders { Diameter (inches); High Pressure Diameter (inches); Low Pressure Stroke (inches)	8½	9½	11	13	15
	17	19	22	26	30
Diameter of driving wheels (inches)	16	18	18	24	24
	30	36	36	46	46
Rigid wheel base (feet and inches)	5-6	5-6	5-9	6-6	6-6
Length over bumpers (feet and inches)	14 to 18	18 to 21	19 to 22	20 to 24	22 to 26
*Extreme width outside gauge at cylinders (inches) (H.P.)	15½	16½	20	23	26
(J.P.)	16¾	17¾	25¼	29½	32¾
*Height above rail (feet and inches)	10-0	11-0	12-0	12-0	12-0
Main reservoir, 2 or 3 tanks capacity (cubic feet)	114 to 210	160 to 290	260 to 375	260 to 375	260 to 375
Main reservoir lengths (feet)	10 to 16	14 to 20	14 to 17	14 to 17	14 to 17
Main reservoir diameters (inches)	30 to 40	32½ to 38½	36 to 40	36 to 40	36 to 40
Main reservoir charging pressure (pounds per square inch)	700 to 1200	700 to 1200	700 to 1200	700 to 1200	700 to 1200
Auxiliary reservoir pressure (pounds per square inch)	250	250	250	250	250
Weight in working order (pounds)	28000 to 36000	32000 to 42000	55000 to 60000	69000 to 73000	95000 to 100000
Tractive force (pounds)	6400	7500	10000	14500	19500
†Hauling capacity in tons of 2000 pounds (exclusive of locomotive), 20 pounds per ton rolling friction:					
On absolute level	305	355	470	689	925
On 1 per cent. grade	145	167	220	326	437
On 2 per cent. grade	92	105	133	205	275
On 3 per cent. grade	65	73	95	145	195
On 5 per cent. grade	38	42	53	84	112
Weight per yard of lightest rail advised (pounds)	40	45	55	65	80
Radius of sharpest curve advised (feet)	50	50	60	70	70
Radius of sharpest curve practicable (feet)	30	30	40	50	50

*This may be decreased in special cases.

†The hauling capacities tabulated above are the maximum for the conditions stated. For satisfactory operation the train weights should be from 50 to 90 per cent. of the above figures.

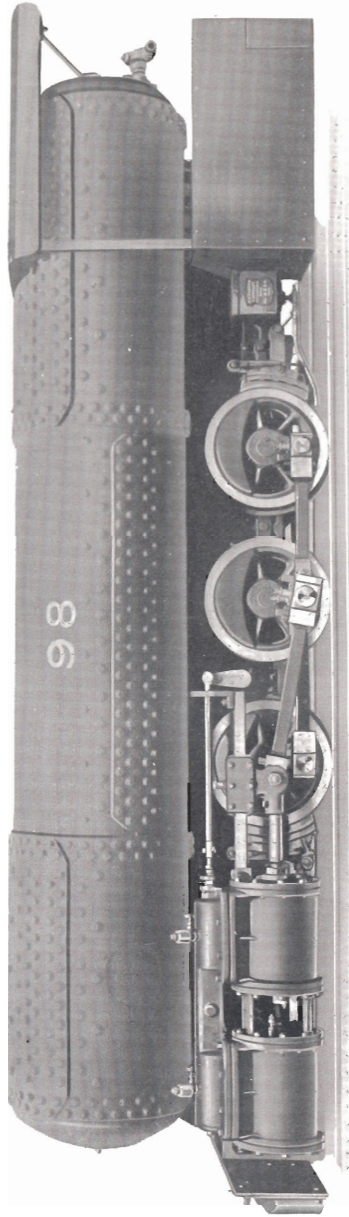

ILLUSTRATION No. 98, CLASS C-PP

Four sizes, each with code word, of the above design are described on the opposite page and the principal dimensions weight, power and other details are given in the column assigned to each size. We are prepared to build other sizes, and to construct these locomotives to any practicable gauge of track and size of entry. Bumpers and draft rising are designed to suit the special requirements of the purchaser. A light canopy to protect the engineer and headlights furnished if required. The dimensions of the locomotive, the pressure and the capacity of the tanks are in every case adjusted to the height and width of entry, length of haul, grades, loads and working conditions. These locomotives run steadily on the rail, pass curves easily and surmount grades as steep as are practicable for any locomotive on ordinary rail. Two inches clearance between the highest point of the locomotive and the lowest place in the entry is abundant, as the height of the locomotive cannot increase, but will decrease a trifle by the wear of tires and journal brasses. Six-wheeled locomotives are used only in cases where the rail is very light and it is necessary to distribute the weight over a greater area of track.

CODE WORD	PEFCOR	PEFDAS	PEFFET	PEFGIS
(Diameter (inches), I.L.P. Diameter (inches), L.P. { Stroke (inches) Diameter of driving wheels (inches) Rigid wheel base (feet and inches) Length over bumpers (feet) *Extreme width outside gauge at cylinders (inches) } I.L.P. { L.P. Extreme width across main reservoir tanks (feet and inches) Height above rail (feet and inches) Main reservoir (2 tanks) capacity (cubic feet) Main reservoir lengths (feet) Main reservoir diameters (inches) Main reservoir charging pressure (pounds per square inch) Auxiliary reservoir pressure (pounds per square inch)	7 14 14 26 26 5-6 14 to 20 14 16½ 5-5 to 6-5 5-0 to 5-10 97 to 160 10 to 18 30 to 36 700 to 1200 250	8½ 12 and 12 14 26 26 5-6 16 to 20 15½ 16¾ 5-5 to 6-5 5-0 to 5-10 114 to 210 12 to 18 30 to 36 700 to 1200 250	9½ 14 and 14 14 26 26 5-6 18 to 21 16½ 17¾ 5-10 to 6-10 5-0 to 5-10 160 to 275 14 to 20 14 to 20 32½ to 38½ 700 to 1200 250	10 14 and 14 14 26 26 6-6 20 to 23 17½ 17¾ 5-10 to 6-10 5-0 to 5-10 160 to 290 16 to 21 16 to 21 32½ to 38½ 700 to 1200 250
	Weight in working order (pounds) Tractive force (pounds) †Hauling capacity—in tons of 2000 pounds (exclusive of locomotive), 20 pounds per ton rolling friction: On absolute level On 1 per cent. grade On 2 per cent. grade On 3 per cent. grade On 5 per cent. grade	2000 to 27000 4400 206 96 59 31 22	28000 to 36000 6400 305 145 92 65 38	32000 to 42000 8000 380 207 113 80 46
Weight per yard of lightest rail advised (pounds) Radius of sharpest curve advised (feet) Radius of sharpest curve practicable (feet)	25 50 30	30 50 30	35 50 30	40 70 50

*This may be decreased in special cases.
 †The hauling capacities tabulated above are a maximum for the conditions stated. For satisfactory operation the train weights should be from 50 to 90 per cent of the above figures.

SPECIAL DESIGNS

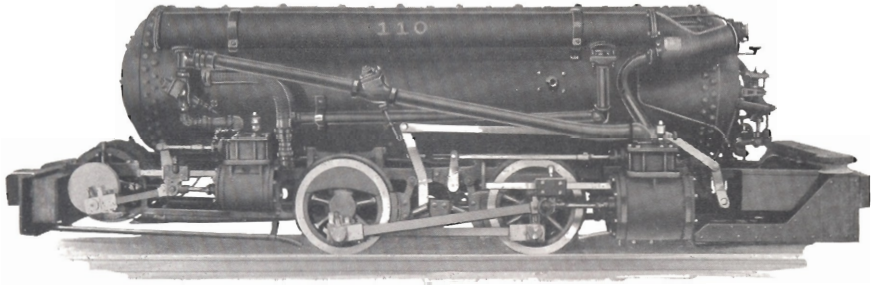

ILLUSTRATION No. 110, CLASS B-P-O, WITH TRACTION REEL

In mines where the vein has a steep pitch the main haulage roads may be driven across the pitch on an easy grade for the operation of locomotives, but the branch entries and chambers leading from these main haulage roads frequently have a very heavy grade. It is to meet such conditions that locomotives with traction reel attachments are designed. They can operate as an ordinary locomotive on comparatively level roads, and as hoisting engines to gather the cars from the steep cross entries and chambers.

They are made in the same sizes as Illustration No. 96, described on a preceding page. We are prepared to build other sizes and to construct these locomotives for any practicable gauge of track and size of entry. Bumpers and draft rigging are designed to suit the special requirements of the purchaser. A light canopy, to protect the engineer, and headlights will be furnished if required. The traction reel engines are designed to develop any required power. The reels will hold from 300 feet to 1000 feet of steel cable, depending upon the dimensions of the reel and the size of cable. The reel revolves freely on the main shaft of the hoisting engine, which has ample bearings in the locomotive frames. For hoisting, the reel is secured to the shaft by means of a clutch. In lowering loads the speed is controlled by a band brake acting directly on the reel and also by the traction reel cylinders acting as compressors. When the clutch is thrown out the cable may be readily unwound by hand. All levers controlling the locomotive, the traction reel engine, clutch and brakes are conveniently located near the engineer's seat at the rear of the locomotive. All parts are accessible for inspection, adjustment, repairs or attaching new cable. The dimensions of the locomotive and the pressure and capacity of the tanks are in every case adjusted to suit the height and width of entry, length of haul, grades, loads and other working conditions. These locomotives run steadily and pass sharp curves easily. Two inches clearance between the highest point of the locomotive and the lowest place in the entry is abundant, as the height of the locomotive cannot increase, but will decrease a trifle by the wear of the tires and journal brasses.

AIR LOCOMOTIVES WITH TENDERS



ILLUSTRATION No. 104, CLASS B-P-T

With cab for surface haulage at powder works, for extra long haul where conditions require light-weight equipment.

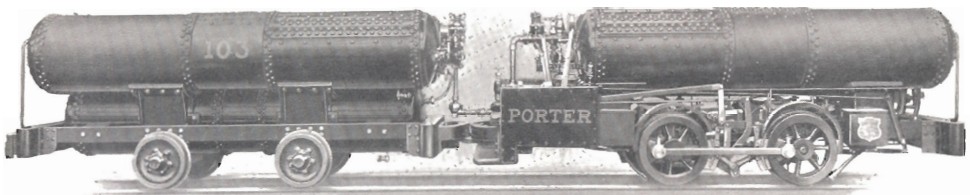

ILLUSTRATION No. 103, CLASS B-PP-T

For mine service with sharp curves and narrow entries requiring locomotive with cylinders inside the frame and with crank axle for main driving wheels.

Under certain conditions tenders are required, as for example, where the head room or side room or weight is so limited that sufficient air cannot be carried on the locomotive to do the required quantity of work on one charge of air.

One feature must be kept in mind when considering the various means by which more air may be carried and the locomotive charged less frequently. It is, that as the capacity of the main reservoir on the locomotive, including the capacity of the tender, increases, it is also necessary to increase the capacity and cost of the stationary storage proportionately, in order that the locomotive may be charged promptly.

Our advice in regard to the best and most economical design for specific conditions and requirements is always at the service of our customers.

FOUR WHEEL CONNECTED WITH TWO FRONT WHEELS
CARRYING LOAD ONLY

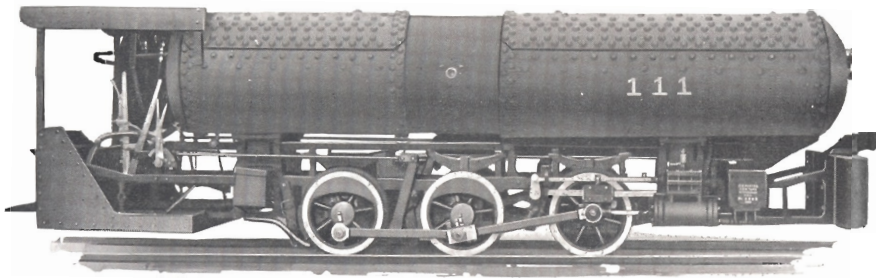

ILLUSTRATION No. 111, CLASS B-2-PP

Another means of enabling a locomotive to make an unusually long trip on one charge is shown by the above illustration. This locomotive has relatively small cylinders and large, long, main reservoir tanks. It has six wheels, four being drivers with the two front wheels used only to help support the weight due to the large tanks. The advantages of this locomotive as compared with the locomotive with tender are that it is more economical, both in first cost and operating expenses, and more convenient to operate where there are no curves which cannot be passed over by a six-wheel locomotive. It is also possible to operate this locomotive on lighter rail than a four-wheel machine. Locomotives of this design were used for the construction of the famous Trans-Andine Tunnel, in South America.

The disadvantages are that it is not so flexible, will not pass as sharp curves and has a longer overhang, which requires more clearance on the outside of the curves.

This type of locomotive is made for all practicable gauges of track and heights and widths of entry

MULTIPLE TANK AIR LOCOMOTIVE FOR VERY HIGH
CHARGING PRESSURE

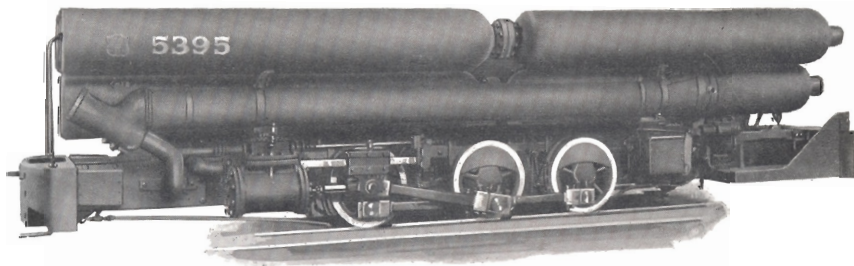

ILLUSTRATION No. 5395, CLASS C-5Ps-O

The above photograph illustrates another method of designing an air locomotive for an extremely long haul on one charge of air. The main reservoir is composed of a number of seamless pressed and drawn steel bottles or tanks, which are built for a working pressure of from 1700 to 2200 pounds per square inch. These tanks are connected to each other so that the pressure is the same in all of them. This locomotive is rather long and has a long wheel-base, and may be used to the best advantage on long, straight hauls. We are prepared to build this type of locomotive for any practicable gauge of track, and for hauls where the height and width are limited.

CONTROLLING DEVICES

The diagrammatic view of the rear end of a two-stage single tank compressed air locomotive, on the preceding page, shows the valves, piping and throttle lever, with all the parts about in their relative positions.

The diagram shows: **First, the course** of the air from the main reservoir to the cylinders; second, the course of the air from the auxiliary reservoir to the interheater by means of the by-pass arrangement; and third, the operation of the various valves.

The air passes from the main reservoir through the elbow "A" and automatic stop valve (as shown by arrows) to the reducing valve. In passing through the reducing valve to the auxiliary reservoir the pressure is reduced to 250 pounds, and from the auxiliary reservoir through the throttle valve (not shown as it is at the front of the locomotive) to the high pressure cylinder.

Ordinarily, the locomotive will start as soon as the throttle is opened; but, if it will not, air must be by-passed from the auxiliary reservoir to the interheater. This operation takes less than five seconds, and is done by means of a hand or foot-operated by-pass valve, which is conveniently located for the locomotive runner to operate.

The air for the by-pass valve passes through a pipe which is tapped into the 45° elbow "B." The by-pass valve is closed by a spring and also by the air pressure. When it is open the air passes through it and through the automatic by-pass stop valve into the interheater pipe, which is connected directly with the interheater. When the interheater gauge registers from 30 to 50 pounds (depending upon the size of the train being hauled), the locomotive is ready to start.

When the locomotive is not using air the throttle valve is, of course, closed and the throttle lever pushed as far ahead as possible. The automatic stop valve cam is then in a position which allows the automatic stop valve to close. The throttle valve then prevents the air from reaching the cylinders, and the automatic stop valve prevents the high pressure air from passing out of the main reservoir. Also, when the throttle is closed the arm on the throttle lever shaft above the automatic by-pass stop valve presses down on the valve stem, allowing the air from the foot by-pass valve to pass into the interheater. When the throttle lever is pulled back to start the locomotive, the spring forces the by-pass stop valve up to its seat, thus, shutting off the by-pass connection to the interheater. The by-pass is only to be used in starting the locomotive, and the by-pass stop valve prevents the operator from using the by-pass while the throttle valve is open.

In pulling the throttle lever back the automatic stop valve cam forces the roller on the stop valve lever up, thus lifting the stop valve from seat and allowing the air to pass from the main tank to the reducing valve.

The function of the reducing valve is to maintain a constant pressure of, usually, 250 pounds in the auxiliary reservoir while the throttle is open. A double seated, balanced valve and an actuating piston are the main working parts of the reducing valve. The air pressure in the auxiliary reservoir acts on one side of the piston, tending to close the valve. This action is opposed by a spring properly adjusted to hold the valve off its seat until the maximum allowable pressure is reached in the auxiliary reservoir, when the pressure of the air overcomes the resistance of the spring and the valve closes.

When the locomotive is to be stopped, the throttle lever is pushed ahead, the throttle valve closes, the automatic stop valve cam allows the stop valve to close, and the automatic by-pass stop valve is opened by the arm above it on the throttle shaft.

SOME OF THE MECHANICAL FEATURES

Common to All Compressed Air Haulage Plants Installed
by the H. K. Porter Company

THE LOCOMOTIVES

The Main Storage Tanks on the locomotives are made of best quality flange steel plates, tensile strength 60,000 to 68,000 pounds per square inch. The longitudinal seams are octuple riveted, with butt joints and welt strip inside and outside; the circumferential seams are double riveted. All rivet holes are drilled after the plates are assembled. The rivets are of soft steel, and are driven by a power riveter capable of exerting a pressure of 300,000 pounds. All caulking is done with round-nosed tools and pneumatic hammers on planed edges. The rear heads of the tanks are spherical in shape, formed by hydraulic pressure from steel plates 35 to 50 per cent. thicker than, and of the same quality as, the cylindrical sheets. In the front heads there is a manhole. These heads are conical in shape in order to properly reinforce the material around the hole. After the heads leave the flanging press they are turned in order to insure a perfect fit. The tanks, after they are completed, are subjected to a test pressure about 30 per cent. greater than the working pressure, and are made absolutely tight at this test pressure. With our designs, the bursting pressure of a tank is so far in excess of the working pressure that absolute safety is insured.

The exceptions to the above method of storage tank construction are as follows:

First: For very high pressure we use seamless steel vessels tested to double the working pressure.

Second: For tanks of small diameter, for ordinary pressures, we use welded wrought iron cylinders, tested to a pressure 50 per cent. in excess of the working pressure.

The Throttle Valve is a special design. We tried the ordinary double-seated locomotive type of throttle valve, but found difficulties in its use, so we designed a single-seated balanced valve which has been found well adapted to the service. It is a compound valve with a small valve, which, opening first, equalizes the pressure on the two sides of the larger valve, which is then readily opened.

The Valves, Links, Frames and Running Gear are in all respects the same as for our standard steam locomotives, except that in general all parts are somewhat heavier and the bearing surfaces somewhat more liberal. The links are fitted with case-hardened, renewable bushings and pins, and are of the skeleton pattern, providing a ready means for taking up wear. The driving boxes and connecting rods are provided with removable bronze bearings, adjustable for wear, and readily renewable. The driving wheels are fitted with steel tires that can be turned two or three times and then renewed. The seats of the slide valves are raised so that they can be faced off in case of wear. *In fact, the entire locomotive is so built that wear is reduced to a minimum, and the parts are so made that when they do become worn it is only necessary to renew the material that is worn.* For example, when a link pin becomes worn, it is only necessary to knock out the old pin and bushing and replace them with the new ones, when the link is as good as before; or if the tread of the driving wheels is so worn that there is a flange on each side of the rail, it may be that the tires will only require turning; but if they are too badly worn for turning, it is simply a question of renewing the tires only, the wheel centers, crank pins and axles remaining intact. The frames are protected from wear by cast iron shoes and wedges. This principle of making the surfaces subject to wear renewable is carried out to the furthest possible degree in every detail of the locomotive construction.

Sand Boxes. Sand is always needed (more especially in mines) to prevent slipping of the driving wheels. Dry sand must be used, and all of our locomotives are equipped with approved sanding apparatus operated by compressed air.

Oiling Devices. The crank pins are supplied with compression grease cups, the cylinders and slide valves with automatic lubricators. The driving boxes are provided with cellars packed with woolen waste, the eccentrics and guides with oil cups of approved design. These are the most important bearings and wearing faces. All others have oil holes conveniently located.

Testing. All locomotives are tested on friction rollers before shipment. They are charged with air at the pressure which they are designed to carry and the combination, regulating and automatic stop valves are carefully adjusted, so that as soon as the locomotive is placed in service it can take up its work with every assurance of satisfactory performance.

Reheating. We are prepared to design and build compressed air locomotives equipped with Reheaters and Interheaters utilizing artificial heat when the conditions of service justify it.

PIPE LINES

When pipe is used for stationary storage, we use a special grade, rolled to our specifications from selected wrought iron skelp, and each length is tested by hydraulic pressure.

We use two forms of pipe coupling—one, the usual sleeve coupling, but of greater weight and recessed at ends for caulking. This form of coupling has given entire satisfaction. It is not intended that all joints should be caulked, but if a leak should occur a strip of soft metal hammered into the recess will put an immediate stop to the difficulty. The other form is a flange coupling designed and manufactured by us. It is intended for use at intervals of 200 to 400 feet, in order that any joint in the pipe line may be easily accessible in case a length of pipe should for any cause require renewal, or in case a change of location should become necessary.

The flange couplings are also sometimes used with bent lengths of pipe. A moderate bend of ten or fifteen degrees can be safely made with the pipe cold, after it has been screwed into the preceding length. But for more acute bends the pipe should be heated and bent before it is placed in position, and then a flange coupling must ordinarily be used.

INSTALLATION AND OPERATION

LOCOMOTIVES

Installation. In lumber yards, manufacturing plants, powder magazines and other surface plants, the installation of compressed air locomotives themselves is a simple operation. It usually consists in unloading the locomotive from a flat car; attaching the grease and the oil cups, lubricators and other fittings, which are packed for shipment; charging with air and starting. When the locomotive is to be used in a shaft mine it must be unloaded and moved to the head of the shaft, then if it is small enough it is run onto the cage and lowered to the bottom. In many cases the locomotive is too long to run onto the cage and is lowered on end. The larger locomotives sometimes have to be taken apart because they are too heavy for the hoisting engines to handle, or too large to be lowered down the shaft in one piece.

Operation. When first starting a locomotive, care should be taken to see that all the working parts are well oiled, so that there will be no danger of any parts becoming heated and scratching or cutting the wearing surfaces.

For use in the cylinders and valve chests we recommend Arctic Ammonia oil, which has a very low cold test. The engineer should be given particular instructions not to use ordinary machine oil in the cylinders. The low temperatures will freeze ordinary machine oil, which adds to the friction of the valves and pistons.

Any ordinarily careful man can operate a compressed air locomotive; he should first be taught the use of the levers, the sanders, the by-pass valve and the location of the different grease and oil cups and oil holes. After he has become a little better acquainted with the machine, he should be taught to inspect it at least once a day and make minor adjustments; other repairs should be reported to a machinist. The best results have been obtained both from men and locomotives by putting one man only on each machine and making him responsible for its satisfactory operation. If he is the right kind of man he will take pride in his machine and keep it well cleaned and oiled.

Inspection and Repairs. Where only a few locomotives are operated the expense of an inspector is not justified and ordinary repairs must be made by the most competent mechanics employed. When extensive repairs are required, as for instance, after a collision or other serious accident, and the mechanical staff at the plant is not familiar with locomotives, it may be more satisfactory to employ one of our traveling engineers for a few days.

Where six or more locomotives are used it will be found that a competent inspector and repairman will earn liberal wages. The locomotive runners report to him each day anything that is out of order on their locomotives, and these reported defects should be the first ones repaired. The repairing can usually be done at night, so as not to interfere with the day's hauling. When no report is made the locomotive should be cleaned and the inspector should examine it for defects that the engineer may have missed, and to see that the engineer is giving the locomotive proper attention while at work.

With this sort of daily inspection and repair the locomotives will always be in their best working condition and will never be out of service more than one night, barring, of course, collisions, derailments and extensive repairs, such as turning down driving wheel tires.

STATIONARY STORAGE

Installation. After the amount of pipe has been calculated and the charging stations located, in most cases, the shortest and most direct connection which can be made between the compressor and charging stations will be the best, but attention must be paid to convenience in laying and accessibility for inspecting and repairing the pipe. The pipe line should be kept in plain sight and as straight as possible; a crooked line costs more than a straight one, although a few bends are a good thing, as they serve to take up expansion.

About every 300 feet a pair of flanges should be placed in the line, and valves at suitable locations, so that repairs, alterations and extensions can be readily made. A valve should also be placed between the compressor and the pipe line, so that the compressor can be inspected or repaired without wasting the air in the pipe line.

Inspection and Repairs. The pipe line, so far as possible, should be uncovered; it is then always open to inspection and the smallest leak at any of the fittings can be readily detected and stopped. All flanges and pipe sockets are counter-bored so that when a leak occurs it may be stopped by caulking with a strip of lead. Compressed air pipe lines, like other metal surfaces exposed to the weather, should be painted with some good non-corrosive coating.

CHARGING STATIONS

Charging stations require but little attention; the valve should be kept tight and the packing ring in the union sleeve replaced if worn out or lost and the ball joints and pipes connecting them should be supported in such a way as to relieve the joints from unnecessary strain at all times.

HIGH-PRESSURE AIR COMPRESSORS

should be in charge of a competent man. They may be driven by a steam engine built in as a part of the compressor, by an electric motor or by a water wheel or by a belt from line shafting. In general they require the same attention that steam engines and low-pressure compressors do; but a man in charge of either high- or low-pressure compressors should be instructed:

To keep his machine clean;

To see that nothing but clean air goes in at the intake;

To keep his valves and pistons tight;

To use a very small quantity of good, high fire-test compressor oil in the compressing cylinders and soap suds about half the time to cut out any accumulated carbon deposits;

To watch the cooling water and to know at all times that it is running freely and filling every water jacket and intercooler;

To watch the pressure gauges on the intercoolers, and when they show abnormal pressure, to hunt the trouble.

He should be told that leaks, dirt, excessive or poor oil and carelessness in regard to cooling water cause 95 per cent. of the compressor troubles, and that the gauges on the intercoolers usually indicate when the compressor is not working properly; that when a compressor runs abnormally hot there is always something that requires immediate attention, usually leaky valves or pistons; that the compressor should be equipped with a fusible plug which, by melting out and releasing a sufficient quantity of air to make an unmistakable noise, will warn him that unusually high temperatures exist, and that the compressor must be shut down, and the cause of the excessive temperature removed; that to neglect these precautions may result in serious damage and possibly personal injury or loss of life.

But these fundamental laws are simple, and a high-pressure compressor is an easy machine to care for. It is equipped with automatic speed and pressure governors and oiling devices, and one man can look after it and several other machines at the same time. But a man who has nothing else to do but look after the compressor can have his days full of trouble if he calls on the compressor to handle a mixture of air, coal dust and sand, and deluges it with poor oil and allows his packing rings and valves to grow leaky and his intercooler tubes to clog up with scale.

CHARGING STATIONS

The charging stations consist of an extra heavy tee or elbow, a special stop valve, a bleeder valve and flexible metallic coupling. The special features of our charging stations are the result of many years' experience; these are the stop valve, flexible metallic coupling and the joint used between the charging station and the locomotive.

We have tried several designs of stop valves, of both the globe and the gate pattern, but none of them would remain permanently tight without constant attention. We then designed and manufactured a stop valve of our own, the main features of which were plenty of metal, a valve seat of case-hardened mild steel and a hard bronze valve, the valve and seat both being easily renewable. The result is most satisfactory; the valves are tight, durable, easy to operate and easily repaired, as the valve seat is so much harder than the valve, it is seldom, if ever, injured. The face of the valve is a plane surface, so that when it becomes worn it is only a few minutes' work to take it out, reface it and replace it.

The flexible metallic coupling consists of three ball joints, three pieces of extra heavy $1\frac{1}{2}$ -inch wrought iron pipe and a special screw coupling. These ball joints are made of bronze and cast-iron, requiring no packing and practically indestructible. The flexible coupling allows the locomotive sufficient latitude, so that delays due to ineffectual efforts to stop the locomotive at exactly the same spot each time are avoided.

Practically every part of the charging check coupling is a special feature. It is composed of a union sleeve, marked (1) in the accompanying figure, a union sleeve packing, marked (2), a coupling nut, (3), coupling nut stop (4), and a check valve (5). The union sleeve fits into the locomotive charging check valve, and a pliable packing ring is fitted into a groove turned in the outside of the union sleeve; under the packing ring are several small holes through which air, at high pressure, passes while the locomotive is charging, forcing the pliable packing out against the inner face of the charging check valve, insuring an air-tight joint that can be quickly connected and disconnected. The coupling nut is threaded four to the inch, so that only a few turns are required to secure the charging station to the locomotive.

In uncoupling the charging station from the locomotive the coupling nut stop, which surrounds the union sleeve just back of the nut, pulls the union sleeve out of the locomotive charging check valve socket.

Locomotive runners, generally, understand that the charging station should be uncoupled and swung back before the locomotive is started, but they have occasionally forgotten to do so. Such forgetfulness might

cause personal injury or loss of life, as well as the loss of compressed air were it not for the emergency device incorporated in the union sleeve. Just under the coupling nut stop a groove has been turned in the union sleeve to make that the weakest point. When the locomotive is started with the charging coupling attached, the union sleeve will break at this point. This piece is cheap and quickly replaced by a new one. A check valve is fitted in the union sleeve, but is held away from its seat by a shoulder. When the union sleeve is broken, this shoulder is carried away and the valve drops on the seat, shutting off the flow of air.

The bleeder valve is used for exhausting the air between the charging station stop valve and the locomotive check valve after the operation of charging is completed.

The entire operation of charging, from the time the locomotive first stops until it starts again with a full charge, seldom occupies more than 1½ minutes and the charging station valve is seldom open more than 40 or 50 seconds for each charge.

COMPARATIVE COSTS OF INSTALLATIONS WITH SINGLE EXPANSION AND TWO-STAGE LOCOMOTIVES

The two-stage locomotive itself costs more than a single expansion machine of the same weight and tractive force, but for a complete installation the operating expenses are not only lower, but the initial cost is less. This is the result of the higher efficiency of the two-stage type which does from 40 to 50 per cent. more work with the same quantity of compressed air. This means smaller boilers and compressors and less expensive pipe lines.

The following tables show approximate first costs, which are relatively correct, of two compressed air equipments, single expansion and two-stage, for doing the same work:

SINGLE EXPANSION

Two single expansion compressed air locomotives at \$2200.00	\$4,400.00
One compressor, capacity 680 cubic feet free air per minute compressed from atmosphere to 1000 pounds	6,000.00
One 250-H.P. boiler, at \$15.00 per H.P.	3,750.00
5500 feet of 4-inch special air line pipe as storage and to convey air to conveniently located charging stations, at 40 cents per foot	2,200.00
Three 4-inch charging stations complete with flanges and bolts for attaching to pipe	250.00
Fittings, valves, etc., necessary for a proper installation	500.00
Foundation for compressor	350.00
Installation of pipe line	500.00
Total cost	\$17,950.00

TWO-STAGE

Two two-stage compressed air locomotives at \$2600.00	\$5,200.00
One compressor capacity 450 cubic feet free air per minute compressed from atmosphere to 1000 pounds	4,500.00
One 175-H.P. boiler, at \$15.00 per H.P.	2,625.00
5000 feet of 4-inch special air line pipe as storage and to convey air to conveniently located charging stations, at 40 cents per foot	2,000.00
Three 4-inch charging stations complete with flanges and bolts for attaching to pipe	250.00
Fittings, valves, etc., necessary for a proper installation	500.00
Foundation for compressor	275.00
Installation of pipe line	450.00
Total cost	\$15,800.00

A comparison of the operating expenses of the two plants considered above is even more striking.

OPERATING EXPENSES AND FIXED CHARGES PER DAY OF NINE HOURS
AND 300 WORKING DAYS PER YEAR

	With Single Expansion Locomotives	With Two-Stage Locomotives
Two locomotive drivers, at \$2.60 each.....	\$5.20	\$5.20
Two brakemen, at \$2.40 each.....	4.80	4.80
Compressor attendance.....	2.00	2.00
Oil for compressor.....	.60	.50
Oil for locomotives.....	.30	.30
Repairs for compressor (material and labor).....	.50	.40
Repairs for boiler.....	.50	.40
Repairs for locomotives (material and labor).....	1.00	1.20
Repairs to pipe line and charging stations.....	.50	.50
Coal to generate steam, 4½ pounds per horse power hour, 10 hours per day, at \$1.00 per net ton:		
4½ × 10 × 250 = 11,250 pounds.....	5.63	
4½ × 10 × 175 = 7,875 pounds.....		3.94
	\$21.03	\$19.24
Daily charge for interest 6 per cent.—Depreciation 5 per cent.— Total 11 per cent.		
\$17,950 × 11 per cent. = \$1,974.50 ÷ 300 = \$6.58 per day.....	6.58	
\$15,800 × 11 per cent. = \$1,738.00 ÷ 300 = \$5.79 per day.....		5.79
Total operating expenses and fixed charges.....	\$27.61	\$25.03
Total cost per ton of material moved one mile.....	1.817c	1.647c

NOTE.—With coal at \$3.00 per ton, the total operating expenses and fixed charges would be \$38.87 with single expansion locomotives and \$32.91 with two-stage, and the cost per ton moved one mile 2.56c. and 2.17c. respectively.

In a plant of this size, therefore, the two-stage locomotive means a saving of about 12 per cent. in first cost and from 9 to 16 per cent. in operating expenses; expressed in money, this would mean a saving of from \$540 to \$1551 per year of 300 working days, depending upon the price of coal. The two-stage locomotive will run so much farther on one charge of air that it usually does away with some of the charging stations and pipe line, but in order to make these comparative estimates conservative, the quantity of pipe was reduced but little, and the number of charging stations left the same. Summing the matter up briefly: A compressed air plant with two-stage locomotives which will save from \$540 to \$1550 a year is worth from about \$4000 to \$12,000 more than a plant equipped with single expansion locomotives, whereas, it costs about \$2100 less.

In making the above estimates it was assumed that the material could not be conveniently handled in trains of more than twenty cars each, that each car had a capacity of 2 tons, and that in order to make 38 round trips, two locomotives were required.

COMPARATIVE COSTS OF INSTALLATIONS

If it had been assumed that the conditions would permit the use of one 40,000-pound locomotive hauling 40-car trains and making 19 round trips per day, the first cost in the case of the two-stage equipment would have been reduced about \$700 and the operating expenses by the wages of one locomotive driver and one brakeman. Under these conditions the operating expenses would have been reduced to $\$19.24 - \$5.00 = \$14.24$, the fixed charges to \$5.56 per day, and the total cost per ton of material moved one mile to 1.32 cents. This reduction in cost per ton mile is due to the fact that the wages of the engineer and brakeman would have been distributed over the entire output, while in the previous case the wages were distributed over one-half of the output, as each locomotive only hauled one-half.

If the condition had been such that smaller locomotives and more of them were required, the operating expenses and fixed charges would have been considerably greater than these items for the plant assumed, because the wages of the engineer and brakeman would have been distributed over a considerably smaller tonnage, the small locomotives not being able to haul as much as the larger ones.

These statements simply show that other items which are readily understood by almost any business man, and are absolutely independent of the relative efficiencies of the two types of machine, greatly influence the economy of hauling.

Other considerations also influence the total cost per ton mile. The length of haul and weight of train greatly affect the consumption of air. A uniform grade of about 1 per cent. in favor of loads will effect a saving in air of about 50 per cent. over a grade of 1 per cent. against the loads and a saving of about 45 per cent. over a level track.

A COMPARISON WITH COMPOUND STEAM ENGINES

In a two-stage compressed air locomotive the air is expanded in successive cylinders, providing for a wider range of expansion, with higher initial and lower terminal pressures. As a two-stage air locomotive is a relatively recent development and compound steam engines are commonly used and generally understood, a comparison will show clearly the much greater gain in efficiency to be obtained with compressed air.

In compounding with steam the end sought is to reduce losses due to initial cylinder condensation, clearance and leakage, and to reduce stresses due to great variation in the total pressure on the piston.

It has been proven that it does not reduce the total quantity of steam used by a compound or triple-expansion steam engine to use interheaters between the cylinders, because the quantity of steam condensed in the interheaters is greater than the saving effected in the steam which passes through the cylinders.

In a compressed air locomotive the temperature of the air entering the high pressure cylinder is that of the atmosphere. It cools itself by doing work in the high-pressure cylinder. When it is thus cooled to a temperature much below that of the surrounding atmosphere, it can, in a properly designed interheater, absorb a great quantity of heat from the atmosphere which is utilized to increase the quantity of work done in the low-pressure cylinder. The heat thus obtained, at no expense, not only increases the work done in the low-pressure cylinder but makes the low-pressure work possible, because unless heat is obtained from an outside source before the air enters the low-pressure cylinder, the temperature, due to further working of the air, would be so low as to interfere with lubrication and satisfactory operation.

Compressed air engines then, with compound cylinders, are successfully used for entirely different reasons and give far better results comparatively than with steam.

These differences in conditions are due to the steam engine being a primary machine for the conversion of heat obtained from fuel into work, whereas, the compressed air locomotive is a machine for converting the heat contained in a quantity of compressed air at about atmospheric temperature into work; and, also, some of the heat in the surrounding atmosphere into work.

By the application of heat, water or any other fluid may be vaporized, and if confined, will exert a pressure which can move a piston in a cylin-

der. To obtain the best results, all losses of heat must be avoided, as the pressure and vaporized condition have been caused by heating the water, and when the excess heat above that of the surrounding materials has been lost, the water again becomes inert and incapable of work. The excess heat of the working fluid above that of the surrounding natural objects is, then, the real source of power.

With air the heat of compression and the refrigeration of expansion are unavoidable evils which must be reduced to a minimum. If the heat of compression could be taken away fast enough to keep the air down to its natural temperature during the entire process of compression, and if heat could be supplied during expansion fast enough to prevent any cooling below that of surrounding objects, or if all of the heat of compression could be retained until the air reached the cylinders in which it is to be expanded and do work, compressed air would be 100 per cent. efficient, barring the losses due to friction of the compressing and expanding engines. Unfortunately, both plans are impossible, more particularly in the case of locomotives. There is not time to extract the heat of compression while the air is in the compressor cylinders, nor to prevent refrigeration while it is expanding in the cylinders of the locomotive. Any heat due to compression remaining in the compressed air after it leaves the compressing cylinders is unavoidably lost before it reaches the working cylinders of the locomotive, because it is necessary to store the air for a considerable time in tanks and pipe lines in order that the locomotive may be charged promptly and at various stations frequently spread over an area of several thousand acres.

In compressing air, the first suggestion—compression without heating—has been approximated by performing the operation in successive cylinders of decreasing size, with intercoolers in which the heat due to the preceding compression is removed. The intercoolers consist of casings filled with small tubes through which cold water is circulated. The air passing through the casings and around the tubes is thoroughly cooled before it enters the next cylinder.

This method of reducing losses in compressors has been in general use since 1890, and all compressors for charging locomotives are of either the three-stage or four-stage type, with either two or three intercoolers, reducing the heat losses from 96 per cent. to 17 per cent., based on isothermal compression.

A great saving in the power required to compress air having been effected by intercooling with water at atmospheric temperature, it was only a short step to the reversal of this process—interheating with water after partial expansion in a high-pressure cylinder, before the air entered

the low-pressure cylinder. This method of utilizing compressed air for driving pumps has been adopted with marked success and greatly increased efficiency. It was a longer step to the substitution of atmospheric air, the only available heating medium which could be drawn on continually while the locomotive was in motion.

A satisfactory method of doing this was not discovered until the H. K. Porter Company built the first two-stage compressed air locomotive with atmospheric interheater, in 1908.

This two-stage operation made possible a higher ratio of expansion with higher initial and lower terminal pressures without unmanageable refrigeration, just as stage compression made possible higher pressures and higher ratios of compression without unmanageable heating.

In a steam engine, because heat put into the steam at the expense of fuel is the immediate source of power, the steam should enter the working cylinders at the highest practicable temperature, be exhausted at the lowest, and all losses due to radiation and convection guarded against in order that the largest possible percentage of heat may be converted into work. In a compressed air locomotive plant, because the heat of compression is lost before the compressed air can enter the working cylinders of the locomotive, the best results are obtained by the closest possible approximation to compression without heating and to expansion without cooling, thereby reducing to a minimum the extra work of compression due to heating, and the work lost due to the cooling of the air during expansion.

Because the performance of the non-condensing compound steam engine has been thoroughly tested by many competent investigators and the increased efficiency, as compared with the single-expansion engine, has been established at about 20 per cent., and as it has been previously stated that the two-stage compressed air locomotive using many of the same appliances will be from 40 per cent. to 60 per cent. more efficient than a single-expansion compressed air locomotive, a brief statement in parallel columns is given in explanation of the greater gain in efficiency.

HIGH PRESSURES TO OBTAIN THE ADVANTAGE OF COMPOUNDING

Two-Stage Compressed Air Locomotive

In order to store compressed air in sufficient quantities to avoid too frequent charging of the locomotive, the air must be compressed to about one-sixtieth of its normal volume and to 800 to 900 pounds pressure. This fundamental requisite provides for a higher pressure in the valve chest of the high-pressure cylinder without additional cost or other compensating disadvantages to obtain it.

Compound Steam Locomotive

Higher steam pressures require a heavier and more expensive boiler; more coal to evaporate a given amount of water into steam at the higher pressure and temperature; more expense for repairs to keep the boiler in working order. The higher temperature of steam at a higher pressure requires better and more expensive lagging for boiler and cylinders to prevent undue losses due to radiation, and better and more expensive packing and lubricants.

RE-HEATING BETWEEN HIGH- AND LOW-PRESSURE CYLINDERS

The compressed air stored in the main reservoir is at atmospheric temperature, because the heat of compression is necessarily lost before the air reaches the locomotive reservoir. For this reason the loss of heat due to the partial expansion of the air in the high-pressure cylinder carries it usually about 140 degrees Fahrenheit, below the temperature of the surrounding atmosphere, thereby rendering the atmospheric air an efficient and inexhaustible heating medium which costs nothing.

Steam in a boiler is at a temperature of from 350 to 600 degrees Fahrenheit, and even after partial expansion in a high-pressure cylinder, is still at a temperature far above that of the atmosphere. It can only be re-heated by burning more coal—and this coal may be used to better advantage in making more steam or hotter steam to be used in the cylinders.

EFFECTS OF INITIAL TEMPERATURES

Two-Stage Compressed Air Locomotive

Compressed air enters the high-pressure cylinder at approximately atmospheric temperature or below, and in expanding and doing work becomes greatly refrigerated. If a high ratio of expansion, with high initial, and low terminal pressures are attempted without restoring the heat lost before the operation is completed, refrigeration becomes so great that proper lubrication is impossible. This lost heat can only be properly restored by dividing the work into two stages and expanding the air in successive cylinders with a properly designed interheater between them. A high ratio of expansion and the resultant economies therefrom are therefore effectively possible in connection with two-stage or multiple-expansion cylinders only.

Compound Steam Locomotive

Steam enters the high pressure cylinder at a relatively high temperature and, as it loses heat due to expansion and work done, becomes cooler. But it is never cold enough to render lubrication more difficult at the lower temperature than the higher. Steam is expanded in two or more successive cylinders to reduce initial cylinder condensation clearance and leakage, and to equalize pressures. There are no other fundamental reasons why a compound or triple-expansion steam engine should be more economical than an engine in which the same ratio of expansion is obtained in a single cylinder.

INDICATOR DIAGRAM

COMBINED INDICATOR DIAGRAMS FOR TWO
 STAGE LOCOMOTIVE IN SOLID LINES.
 INDICATOR DIAGRAM FOR SINGLE EXPANSION
 LOCOMOTIVE IN DOTTED LINES

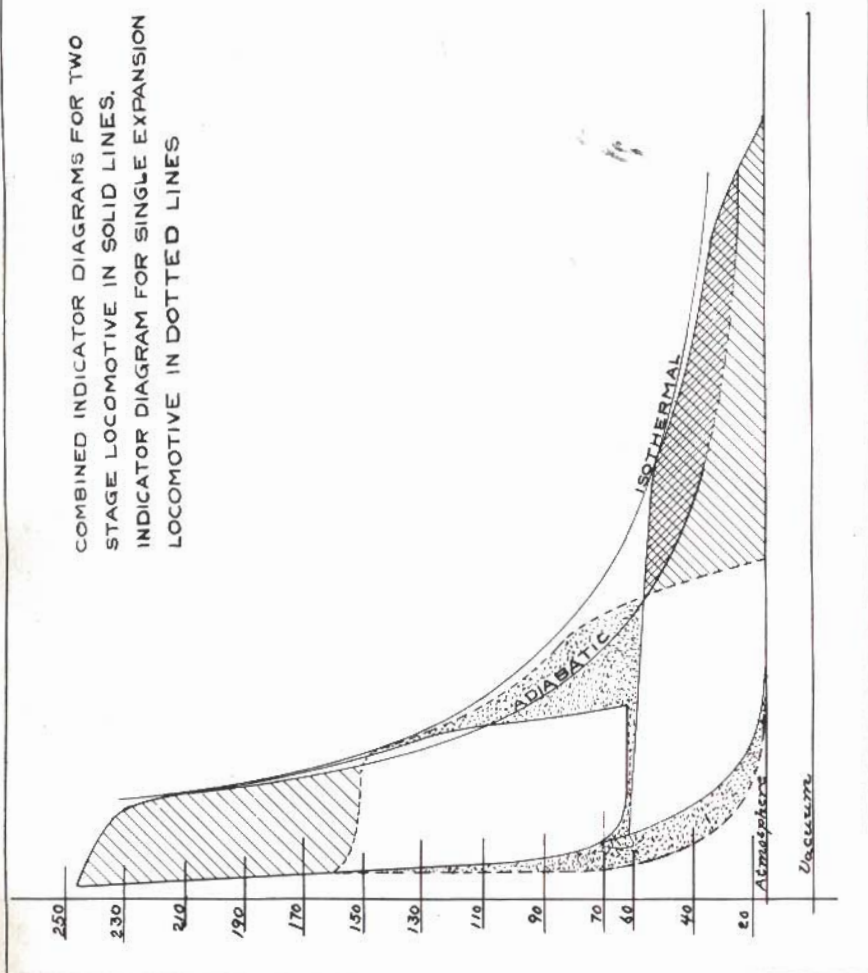

The combined indicator diagrams, page 65, of the two-stage, with superimposed diagram of the single-expansion locomotive, show graphically the actual results which have been obtained. The two long curved lines are the isothermal and the adiabatic. The isothermal curve shows the relations of pressure and volume if the air could be expanded without any reduction in temperature; the adiabatic curve shows the same relations if the air were expanded without obtaining heat from any source except itself. The double-cross-hatched area is the gain due to the interheater alone. The single-cross-hatched area plus the double-cross-hatched area, minus the stippled area, equals the total gain due to the higher initial and lower terminal pressures, with a wider range of expansion in two successive cylinders only possible in conjunction with the use of an interheater to prevent unmanageably low temperatures in the low-pressure cylinder.

A PRACTICAL ILLUSTRATION OF INCREASED EFFICIENCY

In coal and metal mines the two-stage locomotive has been operated in comparison with the single-expansion locomotive, and by the simple test of having first one locomotive and then the other haul the same train over the same piece of track the added endurance on one charge of air, and the superior efficiency of the two-stage machine, has been established.

The following trial was made without special preparations, at the Orient Mine of the Orient Coke Company, Orient, Fayette County, Pa., in the presence of Mr. Charles Oppermann, of the Orient Coke Company, Mr. G. E. Huttelmaier, of the H. C. Frick Coke Company, and Mr. C. B. Hodges, of the H. K. Porter Company. Many others have been made in the same manner with equally good results:

LOCOMOTIVE DATA

	Single Expansion	Two-Stage
Weight.....	9600 pounds	10,500 pounds
Cylinders, high-pressure, diameter.....	6 inches	5½ inches
Cylinders, low-pressure, diameter.....		11 inches
Cylinders, stroke.....	10 inches	10 inches
Driving wheels, number and diameter.....	4-23 inches	4-23 inches
Working pressure, high-pressure cylinder.....	150 pounds	250 pounds
Maximum charging pressure.....	.800 pounds	800 pounds
Storage tanks.....	1	1
Capacity of main reservoir.....	40.26 cubic feet	40.26 cubic feet
Age of locomotive.....	6 months	2 months

ILLUSTRATION OF INCREASED EFFICIENCY

TRAIN AND ROAD DATA

Length of trial run, feet.....	2500
Average up grade, per cent.....	.52
Track gauge, inches.....	44

In this run there was a reverse curve in a chute leading from one heading to a parallel heading. The train consisted of four loaded wagons, each about 7000 pounds, and six empty wagons, each about 2200 pounds.

LOG OF TRIAL RUNS

No. of Run	Tank Pressures			Time (P. M.)			
	Type of Locomotive	At Start	At Finish	Amount of Drop	Start	Finish	Elapsed
1	Single expansion.....	705	265	440	7.23½	7.27½	.04
2	Two-stage.....	740	420	320	8.06½	8.12	.05½
3	Two-stage.....	685	385	300	8.48	8.52¾	.04¾

No. 1 run: Very satisfactory.

No. 2 run: Very irregular; operator not so familiar with two-stage machine, hence decided to re-run.

No. 3 run: Much better and smoother than second.

DEDUCTIONS

Calculated by Mr. G. E. Huttelmaier, H. C. Frick Coke Company.

	Trial No. 1	Trial No. 3
Free air consumed, cubic feet.....	1,206.92	822.90
Drawbar effort { Locomotive 97.92 } { Trip 832.24 }	930.16	939.34
Total work performed in foot-pounds.....	2,325,400.00	2,348,350.00
Foot-pounds performed per minute.....	581,350.00	494,389.00
Average speed { Feet per minute.....	625.00	526.30
{ Miles per hour.....	7.10	5.98
Average horse power developed.....	17.61	14.98
Foot-pounds work per cubic foot, free air.....	1,926.00	2,854.00
Free air consumed per minute.....	301.70	173.24
Air per minute per horse power.....	17.13	11.56
Percentage of air consumed as compared with Trial		
No. 1.....	100 per cent.	67.5 per cent.
Amount of work per unit of air compared to Trial No. 1 ..	100 per cent.	1.48 per cent.
Saving of air effected over Trial No. 1.....		32.5 per cent.

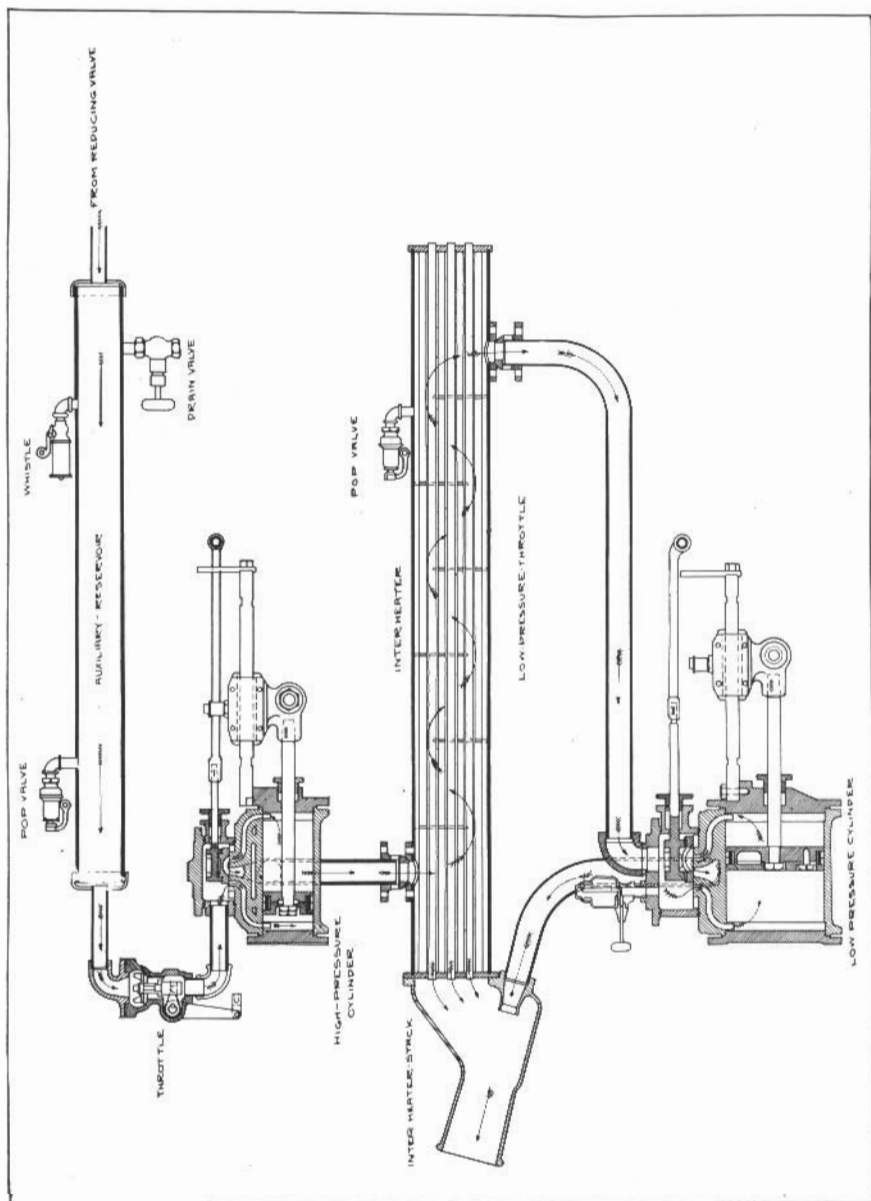

DIAGRAMMATIC VIEW OF CYLINDERS AND INTERHEATER

For ordinary working conditions a cylinder ratio of 4 to 1 has been found most advantageous for two-stage compressed air locomotives (meaning compound locomotives equipped with interheaters). During the partial expansion in the high-pressure cylinder from 250 pounds down to 50 pounds, the temperature of the air ordinarily drops about 140 degrees Fahrenheit, or from about 60 degrees above to 80 degrees below zero, so that on leaving the high-pressure cylinder the volume of the air is only $\frac{460-80}{460+60} = .73$, as great as it would be if no refrigeration had occurred in the high-pressure cylinder. Without the interheater the cut-off volume of low-pressure cylinder could only be $4 \times .73 = 2.92$ times the cut-off volume of the high-pressure cylinder if the initial pressure of 50 pounds per square inch in the low-pressure cylinder is to be maintained. The atmospheric interheating between the high- and low-pressure cylinders expands the air in its passage to make it fill a cylinder $4 \div 2.92 = 1.37$, or 37 per cent. larger than it could otherwise fill with air at a pressure of 50 pounds per square inch, and in so doing adds 37 per cent. to the work done by the air in the low-pressure cylinder, all of which is due to interheating.

The interheater consists of a cylindrical casing filled with small tubes. The partly-expanded and refrigerated air on its way from the high-pressure to the low-pressure cylinder is passed through the casing and around and between the small tubes, while a violent current of relatively warm atmospheric air is being drawn through the small tubes by the partial vacuum created in the base of a slanting draught stack by the ejector action of the exhaust from the low-pressure cylinder.

With an interheater of the relative size shown on page 68, practically all of the heat is restored and the air enters the low-pressure cylinder at a temperature within 15 degrees of that of the surrounding atmosphere. *The temperature of the surrounding atmosphere has no appreciable effect upon the relative economy of this type as compared with the single-expansion locomotive, because the air in the main tank is always at approximately atmospheric temperature however low that temperature may be.* The partially expanded air from the high-pressure cylinder is therefore always colder than the atmospheric air which renders the latter, under all conditions, an efficient heating medium.

MINE HAULAGE

COMPRESSED AIR LOCOMOTIVES, ELECTRIC LOCOMOTIVES AND MULES

Technical papers from time to time publish statements that it costs so many cents or some fraction of a cent per ton mile to haul coal with mules, compressed air locomotives and electric locomotives, the generally accepted hypothesis being that the cost descends from the mule to the electric locomotive, with the compressed air locomotive somewhere in between.

To compare ton-mile costs resulting from the use of various types of motive power, without making a thorough analysis, together with radical corrections to compensate for the effect of conditions and requirements, is apt to be very misleading.

To illustrate, the following is given:

Figures for electric locomotive and mule haulage were taken from Mr. Eli T. Conner's paper, "Anthracite and Bituminous Mining," which was published in the *Coal Age* of November 18, 1911. The mine in which the electric locomotives were operated had a capacity of 8140 gross tons per month; the grades in the rooms were 12 per cent., but no mention was made of the entry grades.

Figures for compressed air and mule haulage were taken from the books of a coal mine in Western Pennsylvania having an output of about 35,000 tons per month. The grades in this mine were variable, some of them in favor of and some of them against the loads, and are as steep as 6 per cent.

The capacity of the car in the compressed air mine was two tons and weighed, empty, 2700 pounds. In the electrically operated mine the car capacity was not definitely stated, but presumably it was about 3000 pounds capacity, the weight of the car itself about 1300 pounds. The comparative figures are given in Table No. 1.

MINE HAULAGE

TABLE No. 1

ACTUAL COST ON THE BASIS OF 553 LOCOMOTIVE HOURS PER MONTH,
OR TWO SHIFTS PER DAY—FOUR-TON ELECTRIC LOCOMOTIVE—
SIX-TON COMPRESSED AIR LOCOMOTIVE—IN GATHERING SERVICE.

	HOURS		HOURLY RATES		AMOUNT		TONS		COST PER TON	
	Elec.	Air	Elec.	Air	Elec.	Air	Elec.	Air	Elec.	Air
Locomotive runners.....	553	553	22½¢	30 ⁵ / ₈ ¢	124.43	168.97	4045.19	10404.6	0.0307	0.0162
Brakemen.....	692	553	20	28 ⁵ / ₈ ¢	138.40	159.76			0.0342	0.0153
Total labor.....					262.83	328.73			0.0649	0.0315
Supplies					18.42				0.0045	
Repairs and Maintenance } ..		553				78.00				0.0075
Power.....		553			18.00				0.0045	
Interest 6 per cent. on \$10,000 for one month					50.00				0.0123	
Interest 6 per cent. on \$5900 for one month.						29.50				0.0028
Depreciation 8 years.....					35.42				0.0088	
Depreciation, 10 per cent.....						49.17				0.0047
					404.67	602.96	4045.19	10404.6	0.1000	0.0578

NOTE. Two shifts is a very decided advantage to either electric locomotives or compressed air locomotives as compared with mules; locomotives can work two shifts whereas mules cannot, thereby distributing the increased interest and depreciation charges of the locomotive over double the number of hours. As a matter of fact the compressed air locomotives only worked one shift but the costs per hour and per ton have been held exactly the same as they actually were with the exception that the interest and depreciation charged are distributed over 553 hours per month and over the coal which would have been gathered in 553 hours had the locomotives continued to work at the same rate which they maintained for nine hours per day and six days in the week. This was done in order to make the cost more truly comparable.

The average length of haul and the cost per net ton mile by the electric and compressed air locomotives are as follows:

Average haul with electric locomotive	3,600 feet
Average haul with compressed air locomotive.....	2,100 feet
Total ton miles, electric locomotive.....	2,758
Total ton miles, compressed air locomotive	4,138
Total cost per ton mile, electric locomotive.....	14.68c
Total cost per ton mile, compressed air locomotive.....	14.55c

It should be observed in connection with the above figures for per ton and ton mile that neither is an accurate basis for estimating the comparative merits of the two types of haulage, more particularly in gathering service, although the same considerations apply to a more limited extent in connection with main haulage. When gathering, the locomotive necessarily spends most of its time in collecting the trip, while the ton

mileage is run up by a long haul between the point where the coal is gathered and the point where it is delivered. The expense of haulage does not run up directly in proportion to the length of the haul, because the time spent in gathering remains a constant regardless of this length of haul. Usually if an analysis of the power expended and time spent in gathering and in hauling the gathered cars to the terminus is made, it will be found that the strictly gathering service is much the most expensive part of the work.

Changing those items in the above table which either are manifestly not chargeable to the type of locomotive or else need correction, Table No. 2 is derived. The figures are for the same locomotives working under the same conditions, but with the engineers and brakemen receiving the same rate of pay, and with the charge for electric power increased from \$20 to \$50 per month, and with the item "Depreciation 8 years \$10,000" raised to \$84.20 per month. The reason for increasing the item of \$20 per month for electrical power is explained in a later paragraph.

TABLE No. 2

	HOURS		HOURLY RATES		AMOUNT		TONS		COST PER TON	
	Elec.	Air	Elec.	Air	Elec.	Air	Elec.	Air	Elec.	Air
Locomotive runners...	553	553	22½	22½	124.43	124.43	4045.19	10404.6	0.0307	0.0120
Brakemen ..	692	553	20	20	138.40	110.60			0.0342	0.0106
					262.83	235.03			0.0649	0.0226
Supplies					18.42				0.0045	
Repairs and Maint'n'ce		553				78.00				0.0075
Power.....		553			18.00				0.0045	
Interest 6 per cent. on \$10,000 for 1 month..					50.00	117.56			0.0123	0.0113
Interest 6 per cent. on \$5900 for 1 month..										
Depreciation 8 years on \$10,000...					84.20				0.0208	
Depreciation, 8 years on \$5900						49.67				0.0047
					483.45	509.75			0.1193	0.0489

MINE HAULAGE

Based on the corrected and equalized figures of Table No. 2, the cost per net ton mile would be: For the electric locomotive 17.55 cents and for the compressed air locomotive, 12.32 cents.

In the same mine where the gathering compressed air locomotives operate, horses are used for gathering coal in another part of the mine. The coal gathered by both the small air locomotives and the horses is hauled to the foot of the shaft by large compressed air locomotives. The cost of gathering by horses in this mine is as follows:

	Day	Week	Cost per Ton
Nine drivers, at \$2.60 per day.....	\$23.40	\$140.40	
One driver at \$2.70 per day.....		16.20	
Total labor.....		\$156.60	\$0.0318
Stable expense.....		83.60	0.0170
Thirteen horses, \$3250; depreciation 5 years.....		12.50	0.0025
Interest, 6 per cent. on \$3250.....		3.75	0.0007
		\$256.45	\$0.0520

With the ten drivers, eleven work horses and two spares, 4918 tons were gathered per week and hauled an average distance of 900 feet, giving the cost per ton in detail as stated above and a total cost per ton mile of 30.6 cents.

The cost per ton for gathering with mules or horses in the electrically operated mine was as follows:

Average distance of mule haul, 1200 feet.

Drivers, 250 hours at 30 cents.....	\$75.00	
" 398 " " 18 ".....	71.64	
" 294 " " 19 ".....	55.86	
" 310 " " 20 ".....	62.00	Cost per Ton
	\$264.50	\$0.0646
Stable boss.....	35.00	0.0086
Blacksmith, shoeing.....	30.00	0.0074
Feed.....	79.20	0.0193
Miscellaneous supplies.....	18.52	0.0043
Depreciation, 5 years.....	25.00	0.0062
Interest, 6 per cent. on \$1500.....	7.50	0.0018
Total.....	\$459.72	\$0.1122

Total cost per ton mile, 39.4 cents.

The coal gathered by the mules in this mine was hauled to the pit mouth, an average distance of 2500 feet, by an electric locomotive.

The comparative figures for main haulage in the two mines under consideration, with electricity and compressed air, were as follows:

TABLE No. 3

	HOURS		RATES		AMOUNT		TONS		COST PER TON	
	Elec.	Air	Elec.	Air	Elec.	Air	Elec.	Air	Elec.	Air
Locomotive runners...	277	277	22½¢	30½¢	62.32	84.64	4095.10	19687.7	0.0153	0.0043
Brakemen ..	346	277	20	28½¢	69.20	80.02			0.0169	0.0041
Total labor					131.52	164.66			0.0322	0.0084
Supplies ..					2.66				0.0006	
Repairs and M'nten'nce					7.24	25.39			0.0018	0.0013
Other r'p'rs and M'n-t'n'nce..					5.71				0.0014	
Power.....					20.00	80.18			0.0049	0.0041
Interest on investment 6 per cent. on \$5000,					25.00				0.0061	
Interest on investment 6 per cent. on \$8650,						43.25				0.0022
Depreciation, 8 years...					17.71				0.0042	
Depreciation 8 years on \$8650						72.83				0.0037
					209.83	386.31			0.0512	0.0197

In Table 3, the electric locomotive moved the coal an average distance of 2500 feet and the compressed air locomotive an average distance of 3400 feet, so the comparative costs per ton mile are:

For Electricity: $\frac{2500 \times 4095}{5280} = 1938$ ton miles.
 $\frac{209.83}{1939} = 10.83$ cents per ton mile.

For Air: $\frac{3400 \times 19,688}{5280} = 12,677$ ton miles.
 $\frac{386.31}{12,677} = 3.05$ cents per ton mile.

MINE HAULAGE

In explanation of the correction of the figure of \$20 per month for electrical power as given in Table 1 and increased to \$50 in Table 2, the following is offered:

The cost of power per ton mile for gathering and main haulage is as follows:

Cost for power in gathering, \$20.00.

The calculated ton mileage, 2758.

$$\frac{\$20.00}{2758} = \$0.00726 \text{ per ton mile.}$$

$$\text{For main haulage, } \frac{\$20.00}{1939} = \$0.01033 \text{ per ton mile.}$$

It will be seen from these calculations that the cost for power per ton mile is 42 per cent. greater for the main haulage than for the gathering service. The relative costs for power per ton mile in the same two services in the mine operated by compressed air were:

$$\text{For gathering: } \frac{\$117.56}{4138} = \$0.0284 \text{ per ton mile.}$$

$$\text{For main haulage: } \frac{\$80.18}{12,677} = \$0.0063 \text{ per ton mile.}$$

These figures show the cost for power per ton mile for gathering with compressed air locomotives to be 4.48 times as great as it is for main haulage. There are many reasons why the cost for power per ton mile for gathering should be much more than for main haulage, but none why it should be less, unless a condition where all of the main haulage is up hill and all of the gathering is down hill might be cited as an exception.

In all of the above figures it is the ton of coal moved one mile in the desired direction that is considered. In actual service the cars and the locomotive must be moved as well as the coal, and because the car and the locomotive must move approximately twice as far as the coal in order to get the cars back empty to the loading place, the gross ton mileage is about twice the net ton mileage for main haulage. For gathering work the gross ton mileage will be from four to six times the net ton mileage, because in gathering cars from the rooms the locomotive must make many movements with only one car or without any cars. While doing this work the percentage of net to gross is exceedingly low, as the locomotive itself forms such a large part of the total weight of the moving train.

Any remaining inconsistency in the relative costs for compressed air locomotives in main haulage and gathering service is readily accounted for by considering the following adverse conditions as compared with locomotives operating in main haulage service: Ordinarily, the gathering locomotive has poorer track than the main haulage locomotive, a greater percentage of curved track, more frequent stops and starts and a somewhat lower efficiency because of handling only one car at a time instead of being loaded approximately to capacity.

From the previous considerations taken in conjunction with the relative figures for the compressed air locomotive it seems certain that the figure of \$20 for electric power for the gathering locomotive needs correction, more especially as this locomotive operated two shifts while the main haulage locomotive only operated one shift per day.

It costs 10 cents a ton to gather and haul 4045 tons of coal per month in two shifts with one electric locomotive, and it costs 16.34 cents per ton to gather 4095 tons of coal with mules and haul it 2500 feet to the pit mouth. It would seem from these results that there was a saving in gathering by electric locomotives of about 4 cents per ton, but the fallacy of arriving at a conclusion too hastily without giving due consideration to the different conditions which affect the cost of hauling is clearly shown in the following paragraph:

In the compressed air mine which was investigated the coal was gathered and hauled an average distance of 900 feet by mules at a cost of 5.2 cents per ton, and was afterward hauled an average distance of 3400 feet with main haulage compressed air locomotives at a cost of 1.97 cents per ton, giving a total cost for gathering and hauling of 7.17 cents per ton, a lower figure than any quoted for electricity. This figure is also slightly lower than the results achieved with compressed air gathering and main haulage locomotives in sections of the same mine where the compressed air gathering locomotives were working but one shift, giving the following results:

Gathering by compressed air locomotives.....	6.72 cents a ton
Main haulage.....	1.97 cents a ton
Total cost.....	8.69 cents a ton

as against 7.17 cents a ton with mules and main haulage compressed air locomotives. This shows that in the compressed air mine the coal was delivered to the shaft bottom cheaper with mules and main haulage locomotives than with gathering compressed air locomotives and main haulage locomotives; but in order to achieve these results with the mules it is necessary to keep the mule haul down to 900 feet or less in order to enable the mules to gather, as they did, 41.6 two-ton cars per

mule. If the mules had to haul the coal an average distance of 1200 feet, as the gathering locomotives did, and had been forced to encounter the adverse grades which the locomotives did, the cost for mule haulage would have been 50 per cent. greater, throwing the balance again in favor of the gathering locomotives. In other words it was only possible to obtain the good results with mules which were obtained in this mine by working them in selected places under the most favorable conditions.

All of this goes to show that it is extremely dangerous to draw general conclusions in regard to the relative economy of the various types of haulage unless careful consideration is given to existing conditions, some of which are lengths of haul, grades, weights, and capacities of cars, initial cost, and cost of upkeep of horses and mules in different sections of the country, and the cost of power. The foregoing figures in regard to the relative cost of haulage by electricity and compressed air do not necessarily represent with any degree of accuracy the relative merits of the two systems. The much greater tonnage handled by the compressed air locomotives gives them a very decided advantage.

There is a lamentable dearth of accurate information in regard to the relative costs of the various systems of haulage. Many of the opinions expressed in regard to relative economy are founded largely on prejudice, with little or no basis of accurate information, and a consideration of the above figures in regard to capacity and performance show that the relative costs of haulage by the two systems depend more upon their intelligent installation and handling than upon either type of haulage, and that with equal energy and experience the difference in the cost of haulage by either system will only appear as small fractions of a cent. Further they show that if the mule haul can be kept short and the grades not too steep, the mule in gathering service is a close competitor of either type of locomotive and will remain so until the general advent of the three- or four-ton mine car enables the locomotive to get more coal each time it makes a trip up the room.

HORSE POWER DEVELOPED TO COMPRESS 100 CUBIC FEET FREE AIR FROM ATMOSPHERE TO VARIOUS PRESSURES

Gauge pressure, pounds	One-stage compression D. H. P.	Gauge pressure, pounds	ASSUMING PERFECT COOLING BETWEEN STAGES		
			Two-stage compression D. H. P.	Three-stage compression D. H. P.	Four-stage compression D. H. P.
5	1.96	60	11.70	11.20	10.80
10	3.60	70	12.70	12.00	11.70
15	5.03	80	13.70	13.00	12.50
20	6.28	90	14.70	14.00	13.50
25	7.42	100	15.40	14.50	14.20
30	8.47	125	17.50	16.00	15.60
35	9.42	150	19.00	17.50	16.70
40	10.30	200	21.20	19.50	18.75
45	11.14	300	24.50	22.90	21.80
50	11.90	400	27.70	25.70	24.00
55	12.67	500	29.75	27.60	25.90
60	13.41	600	31.70	29.20	27.50
70	14.72	700	33.50	30.60	28.90
75	15.37	800	34.90	31.80	30.00
80	15.94	900	36.30	32.90	31.00
85	16.50	1000	37.80	33.80	31.80
90	17.06	1200	39.70	35.50	33.30
100	18.15	1400	41.60	36.80	34.60
150	24.00	1600	43.00	38.10	35.65
200	26.20	1800	44.50	39.30	36.70
400	36.00	2000	45.50	40.60	37.80
...	2500	39.06
...	3000	40.15

An addition of 10 to 15 per cent. should be made for friction and intake temperature higher than 60 degrees Fahrenheit, on which this table is based. Atmospheric pressure is assumed at 14.7 pounds per square inch. No account taken of jacket cooling.

EFFECT OF ALTITUDE

**EFFECT OF ALTITUDE UPON THE QUALITY OF AIR COMPRESSED AND
POWER REQUIRED WHEN THE TERMINAL PRESSURE IS 1000 POUNDS
PER SQUARE INCH.**

Altitude, feet above sea level	BAROMETRIC PRESSURE		Volume at 60° F. of one pound of air, in cubic feet	Per cent. of sea level air per cubic foot of piston displacement	Decreased power required per cent. in compressing one cu. ft. of the free air available at the altitude to 1000 pounds gauge pressure*
	Inches mercury	Pounds per square inch			
0	30.00	14.72	13.14	100
1000	28.88	14.15	13.70	97	2.5
2000	27.80	13.62	14.18	93	5.3
3000	26.76	13.11	14.75	90	8.0
4000	25.76	12.62	15.30	86	10.5
5000	24.79	12.15	15.92	83	13.0
6000	23.86	11.68	16.54	80	15.4
7000	22.97	11.25	17.18	77	17.7
8000	22.11	10.82	18.85	73.5	20.0
9000	21.29	10.42	18.51	70.5	22.3
10000	20.49	10.04	19.25	68	24.5
11000	19.72	9.67	20.00	66	26.5
12000	18.98	9.31	20.79	64	28.5
13000	18.27	8.95	21.58	61	30.6
14000	17.59	8.62	22.43	59	32.6
15000	16.93	8.30	23.34	57	34.5

*The error will not be serious in assuming that the per cent. decreased power required is correct from 800 to 1200 pounds delivery pressure.

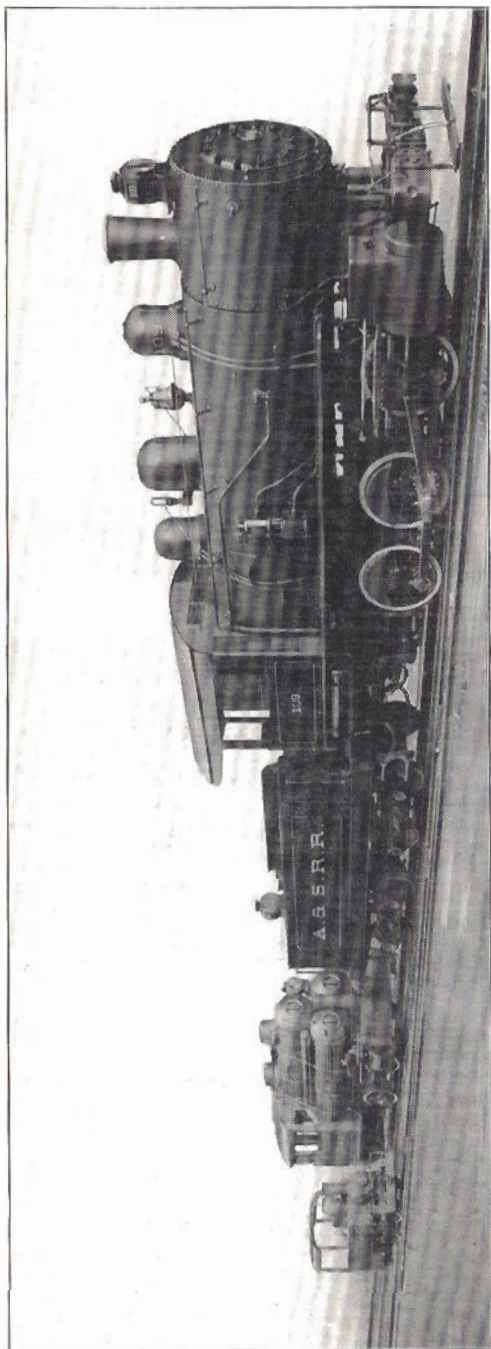

NARROW GAUGE 5-TON
LOCOMOTIVE FOR EXPORT

STANDARD GAUGE TWO-STAGE AIR LOCOMOTIVE.
ONE OF A NUMBER FOR U. S. NAVAL MAGAZINES

75-TON 6-WHEEL STANDARD GAUGE
SHIFTER WITH TENDER

H. K. PORTER COMPANY

build steam locomotives, 3 to 100 tons weight, for extra narrow, narrow, wide and extra wide gauges of track—every variety of design—for coal, wood or oil fuel—and for use all over the world.

Completed locomotives in assorted sizes, wide and narrow gauge, always on hand for immediate delivery. The Porter Eleventh Edition Steam Catalogue and Cable Code free to intending purchasers. Address

H. K. PORTER COMPANY

Cable Address: Porter, Pittsburgh

1200 Union Bank Building, Pittsburgh, Pa., U. S. A.

