

**STEAM  
LOCOMOTIVE  
REPAIR PARTS**



**H. K. PORTER COMPANY**

**PITTSBURGH, PA., U.S.A.**

**1913**

# STEAM LOCOMOTIVE REPAIR PARTS



H. K. PORTER COMPANY

PITTSBURGH, PA., U. S. A.

EDWARD STERN & CO., INC.  
PRINTERS      ENGRAVERS  
PHILADELPHIA   NEW YORK

# Preface

**T**HIS catalogue is intended for use in ordering detail parts of our Steam Locomotives. To assist in identifying the parts required the plates show each detail bearing a number which refers to a name in the list opposite the plate. Each numbered detail part has been given a code word for the sake of brevity in ordering. In addition to this, code words have been given to several items without numbers, which are marked "complete." This is also for brevity in ordering.

*Each item marked "complete" is composed of the parts in lighter faced type directly following it.*

**Please use this catalogue in making out every order  
to us for Locomotive Repair Parts**

Always state whether repair parts are to be shipped by PARCEL POST, EXPRESS or FREIGHT, and mention the express company or the delivering railroad, if there is any preference.

State the BUILDER'S locomotive NUMBER with each order. It is the only means by which the locomotive can readily be identified in the Shop Records.

We carry in stock, independent of parts of locomotives under construction, fitted parts for all our standard sizes and designs ready to ship.

RIGHT SIDE and LEFT SIDE mean the engineer's right side and left side as he stands in the cab facing toward the front end of the locomotive.

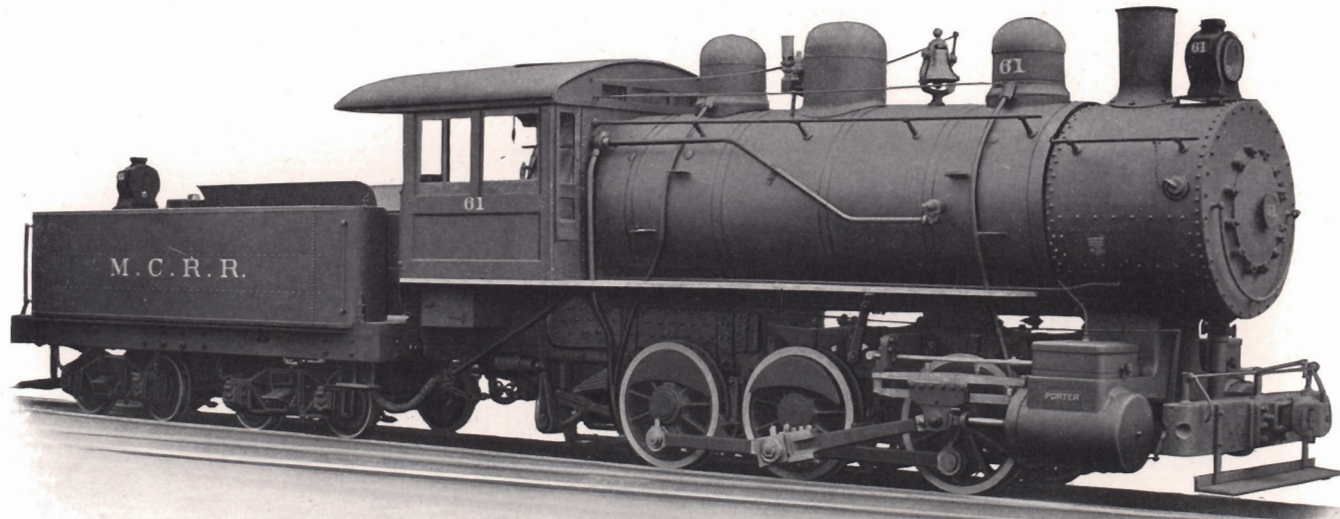

Cylinders.....20" x 26"  
Boiler Pressure ..... 200 lbs.  
Tractive Force ..... 35,360 "  
Weight.....150,000 "

Rigid Wheel Base.....11' 0"  
Driving Wheel Diameter.... 50"  
Tender Weight .....90,000 lbs.  
Water.....5,000 gals.

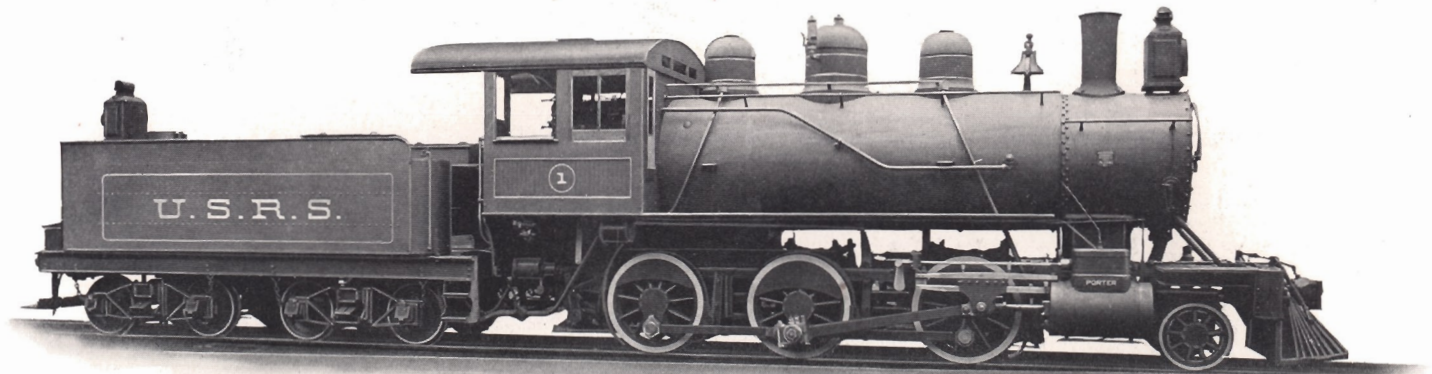

Cylinders ..... 18" x 24"  
Boiler Pressure ..... 180 lbs.  
Tractive Force ..... 23,790 "  
Weight ..... 115,000 "

Rigid Wheel Base ..... 12' 6"  
Driving Wheel Diameter .... 50"  
Tender Weight ..... 70,000 lbs.  
Water ..... 3,500 gals.



Cylinders . . . . . 12" x 16"  
Boiler Pressure . . . . . 155 lbs.  
Tractive Force . . . . . 9,200 "  
Weight . . . . . 42,000 "

Rigid Wheel Base . . . . . 5' 0"  
Driving Wheel Diameter . . . . . 33"  
Saddle Tank . . . . . 700 gals.  
Coal . . . . . 600 lbs.



H . K . P O R T E R C O M P A N Y

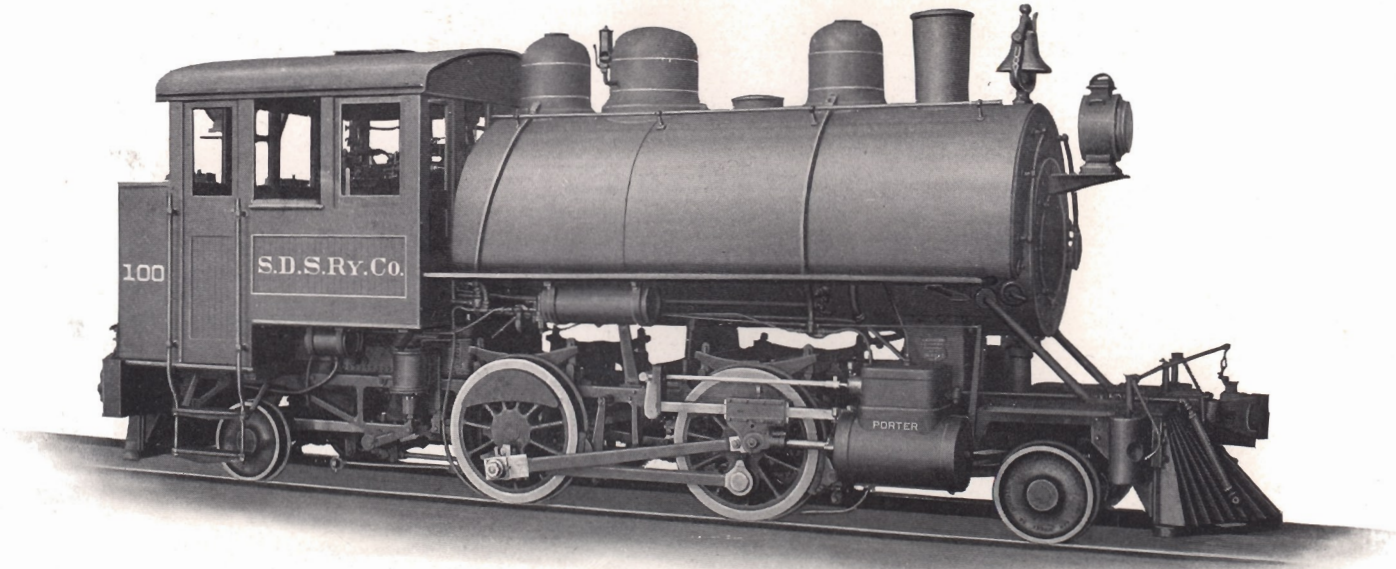

Cylinders ..... 14" x 20"  
Boiler Pressure ..... 170 lbs.  
Tractive Force ..... 12,875 "  
Weight ..... 78,000 "

Rigid Wheel Base ..... 6' 3"  
Driving Wheel Diameter .... 44"  
Saddle Tank ..... 1,000 gals.  
Oil Fuel ..... 600 gals.





PLATE 1

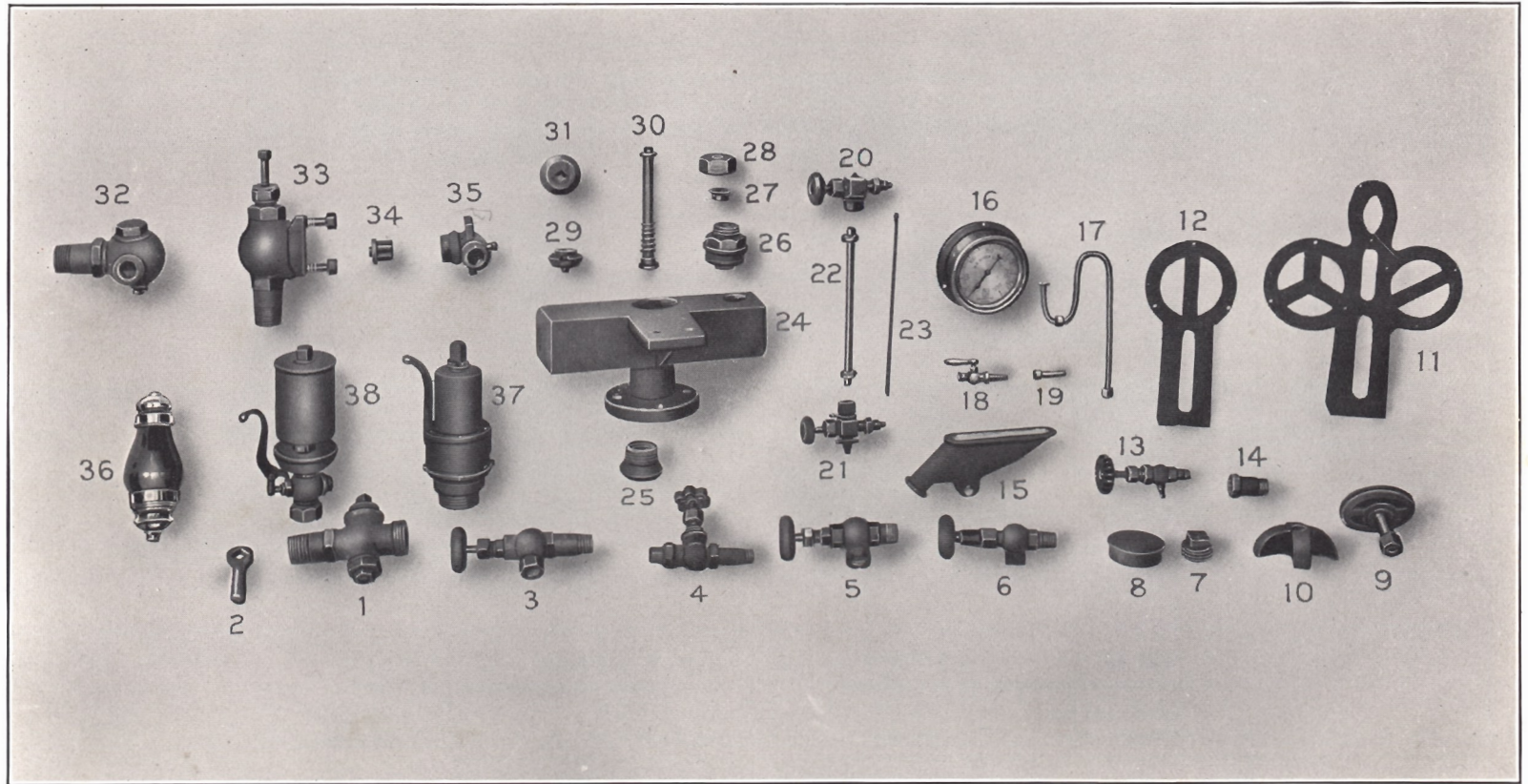



**BOILER DETAILS**

**PLATE 1**

CODE WORD	No.	NAME OF PART	CODE WORD	No.	NAME OF PART
MAABE	1	Blow-off Cock			<b>WATER GAUGE</b> (Continued)
MAACI	2	Blow-off Cock Handle	MABOG	22	Water Gauge Glass (With Gaskets)
MAADO	3	Injector Steam Valve	MABUH	23	" " " Guard
MAAFU	4	Lubricator Steam Valve	MABVE		<b>STEAM BOX</b> (Complete)
MAAGY	5	Injector Steam Valve	MABYK	24	Steam Box Body
MAAHZ	6	Blower Valve	MACAD	25	" " Ball Joint
MAAKS	7	Mud Plug	MACBO	26	" " Bonnet
MAALC	8	Mud Plug Cover	MACCU	27	" " Gland
MAANT	9	Hand Hole Cover	MACDY	28	" " " Nut
MAARD	10	Hand Hole Cover Clamp	MACEF	29	" " Valve
MAASP	11	Gauge Stand	MACFA	30	" " " Stem
MAATH	12	Gauge Stand	MACGE	31	" " " " Handle
MAAWG	13	Gauge Cock	MACIG	32	<b>Injector Check</b> (Specify Right or Left)
MAAYA	14	Gauge Cock Extension	MACOH		<b>INJECTOR CHECK</b> (Complete)
MABAC	15	Gauge Cock Dripper	MACUJ	33	Injector Check Body (With Hand Valve)
MABBI	16	Steam Gauge	MAJVI	34 ✓	" " Valve
MABCO	17	Steam Gauge Syphon	MACYL	35 ✓	" " Elbow
MABDU	18	Steam Gauge Cock	MADAF		<b>CAB LAMP</b> (Complete)
MABED	19	Steam Gauge Cock Extension	MADBU	36	Cab Lamp Globe
MABFY		<b>WATER GAUGE</b> (Complete)	MADCY	37	<b>Pop Valve</b> (Specify Pressure)
MABGA	20	Water Gauge Cock (Upper)	MADDA	38	<b>Whistle</b>
MABIF	21	" " " (Lower)			

Specify **BUILDER'S** locomotive **NUMBER** and **CODE WORD** with each order.



PLATE 2

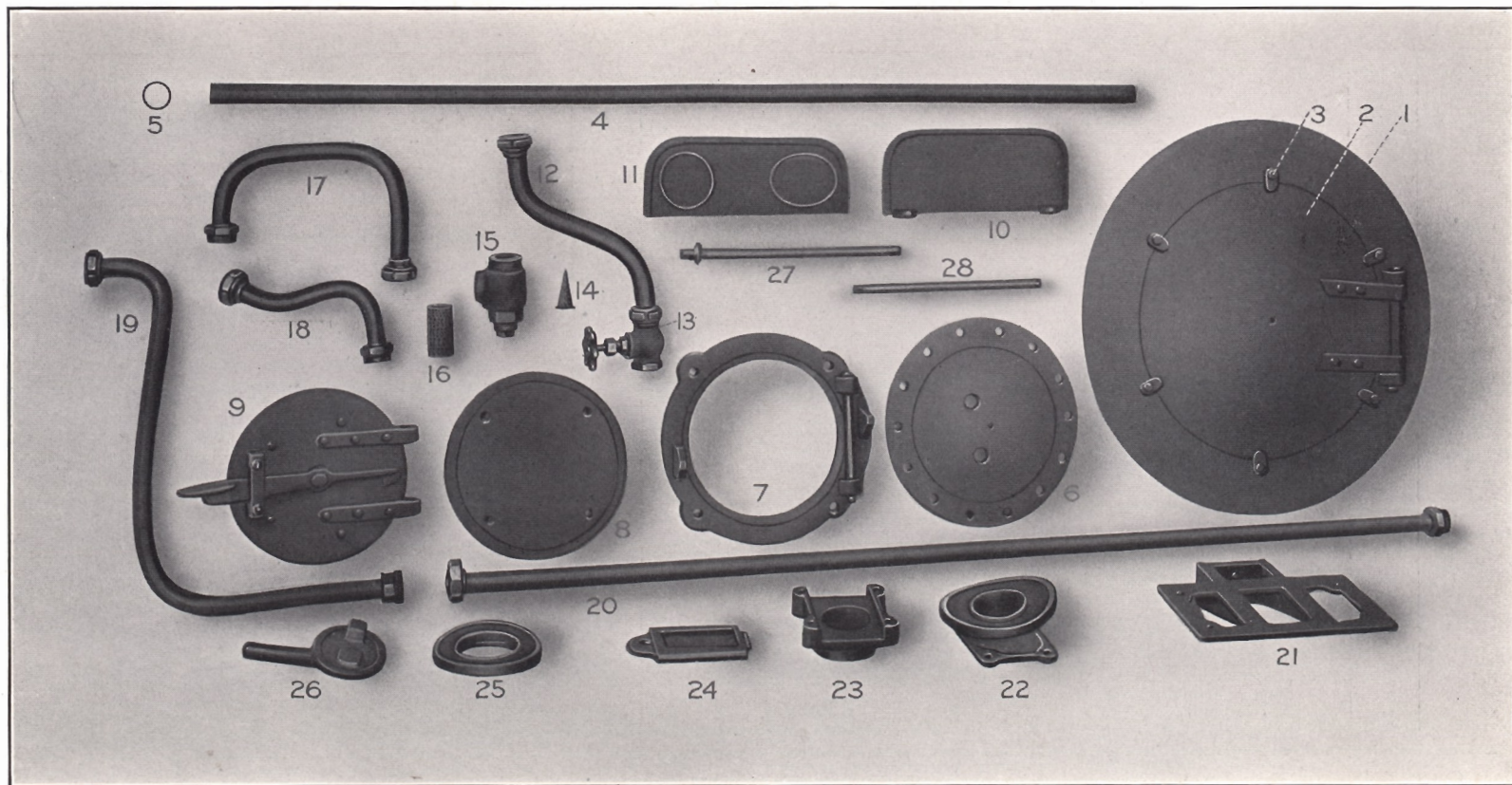



**BOILER DETAILS**

**PLATE 2**

<b>CODE WORD</b>	<b>No.</b>	<b>NAME OF PART</b>	<b>CODE WORD</b>	<b>No.</b>	<b>NAME OF PART</b>
MADEG	1	<b>Boiler Front</b>	MAFCA	*	<b>INJECTOR DISCHARGE PIPE</b> (Complete)
MADFE	2	<b>Boiler Door</b>	MAFDE	*19	Injector Discharge Pipe (Bent)
MADGI	3	<b>Boiler Door Clamp</b>	MAFEH	*20	“ “ “ (Straight)
MADIH	4	<b>Boiler Flue</b>	MAFFI	21	<b>Headlight Shelf</b>
MADOJ	5	<b>Boiler Flue Ferrule</b>	MAFGO		<b>CINDER HOPPER</b> (Complete)
MADUV	6	<b>Dome Cap</b>	MAFIJ	22	Cinder Hopper Frame (Upper)
MADVO	7	<b>Firedoor Frame</b>	MAFOK	23	“ “ “ (Lower)
MADYM	8	<b>Firedoor Liner</b>	MAFUL	24	“ “ Slide
MAEBZ	9	<b>Firedoor</b>	MAFVU	25	<b>Poke Hole Frame</b>
MAECS	10	<b>Firedoor Shade</b>	MAFYN	26	<b>Poke Hole Cap</b>
MAEGN	11	<b>Firedoor Shade</b>	MAFAH	27	<b>Radial Staybolt</b> (With Head)
MAEHC	*	<b>INJECTOR WATER PIPE</b> (Complete)	MAFBA	28	<b>Staybolt</b> (Plain)
MAELD	*12	Injector Water Pipe (With Collars)			
MAERF	13	“ “ Valve			
MAESH	14	<b>Injector Water Strainer</b> (Copper Cone)			
MAEWB		<b>INJECTOR WATER STRAINER</b> (Complete)			
MAEXT	15	Injector Water Strainer Body			
MAEYE	16	“ Copper Water Strainer (Inside of Body)			
MAFAG	*17	<b>Injector Steam Pipe</b>			
MAFBY	*18	<b>Injector Steam Pipe</b>			

\*Specify whether for **RIGHT** or **LEFT** side of locomotive.

Specify **BUILDER'S** locomotive **NUMBER** and **CODE WORD** with each order.



PLATE 3

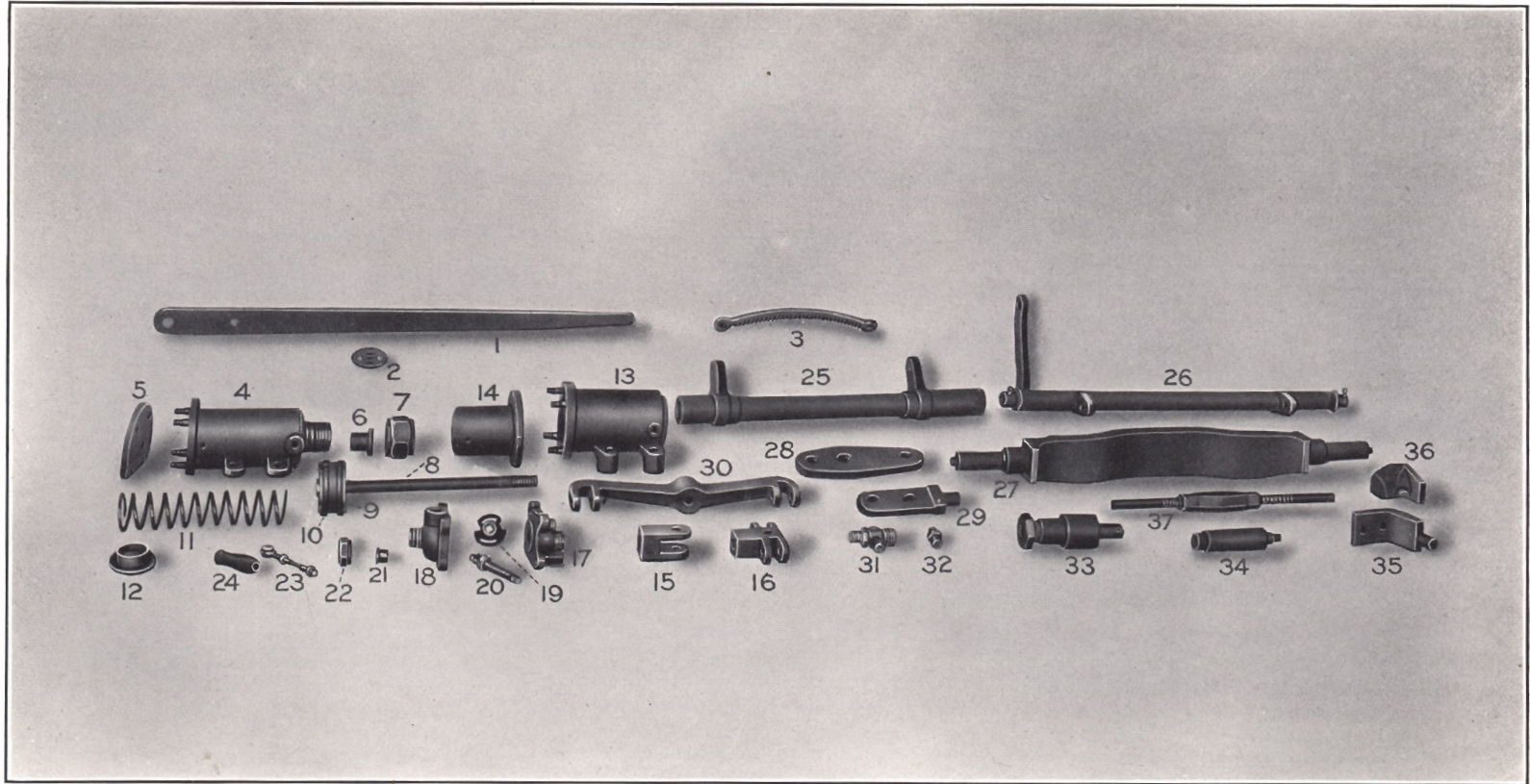



Steam and Hand Lever Brakes for Driving Wheels

PLATE 3

CODE WORD	No.	NAME OF PART	CODE WORD	No.	NAME OF PART
MAGCE		<b>HAND BRAKE</b> (Complete)	MAIGH		<b>ENGINEER'S BRAKE VALVE</b> (Complete)
MAGDI		<b>STEAM BRAKE</b> (Complete)	MAIHB	17	Engineer's Brake Valve Body
MAGEJ	1	<b>Brake Hand Lever</b>	MAILG	18	" " " Cap
MAGFO	2	<b>Brake Hand Lever Latch</b>	MAINK	19	" " Valve (Brass)
MAGGU	3	<b>Brake Quadrant</b>	MAIRJ	20	" " " Stem
MAGIK		<b>BRAKE CYLINDER</b> (Complete)	MAISY	21	" " " " Gland
MAGOL	4	Brake Cylinder Body	MAIWC	22	" " " " " Nut
MAGUM	5	" " Head	MAIYS	23	" " " Handle (Brass)
MAGVY	6	" " Gland	MAJAK	24	" " " " (Wood)
MAGYO	7	" " " Nut	MAJEL	25	<b>Brake Shaft</b> (Cast Steel)
MAHAJ	8	" " Piston Rod	MAJIM	26	<b>Brake Shaft</b> (Wrought Iron)
MAHBE	9	" " " Head	MAJON	27	<b>Brake Beam</b>
MAHCI	10	" " " Ring	MAJUP	28	<b>Brake Floating Lever</b>
MAHDO		<b>BRAKE CYLINDER WITH SPRING POCKET</b> (Complete)	MAJYR	29	<b>Brake Floating Lever</b>
MAIBS	13	Brake Cylinder Body	MAKAL	30	<b>Brake Cylinder Beam</b>
MAICH	14	" " Spring Pocket	MAKEM	31	<b>Brake Cylinder Drip Valve</b>
MAHAJ	8	" " Piston Rod	MAKIN	32	<b>Brake Cylinder Drip Valve</b>
MAHBE	9	" " " Head	MAKOP	*33	<b>Brake Hanger Pivot</b>
MAHCI	10	" " " Ring	MAKUR	*34	<b>Brake Hanger Pivot</b>
MAHEK	11	" " Spring	MAKYS	*35	<b>Brake Hanger Pivot</b>
MAHFU	12	" " " Washer	MAKZT	36	<b>Brake Rod Adjusting Block</b>
MAIDZ	15	<b>Brake Piston Rod Crosshead</b>	MAKXU	37	<b>Brake Hand Turn Buckle</b>
MAIFT	16	<b>Brake Piston Rod Crosshead</b>			

\*Specify whether **FRONT**, **INTERMEDIATE**, **MAIN** or **REAR**.  
Specify **BUILDER'S** locomotive **NUMBER** and **CODE WORD** with each order.



PLATE 4

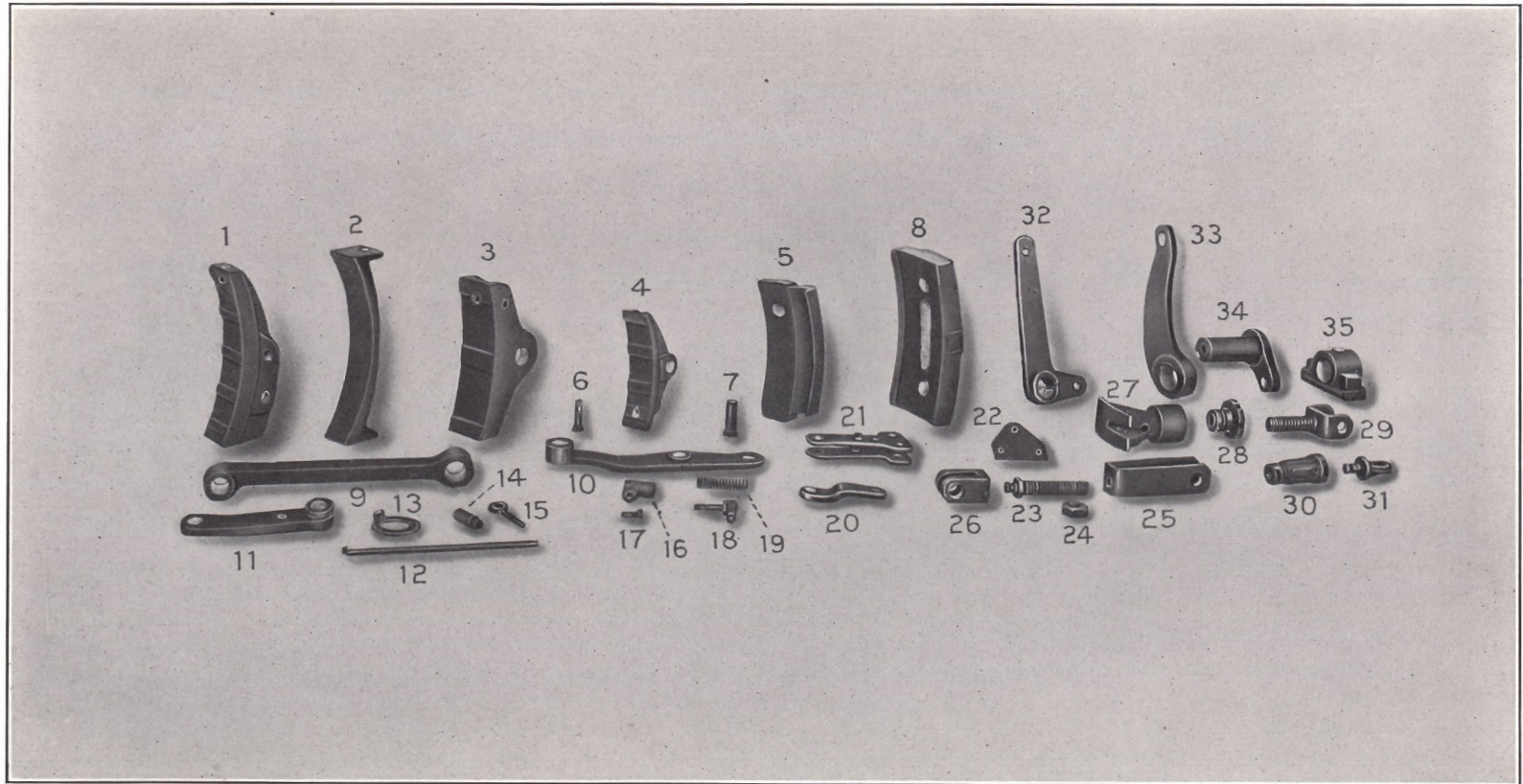



Steam and Hand Lever Brakes for Driving Wheels

PLATE 4

CODE WORD	No.	NAME OF PART	CODE WORD	No.	NAME OF PART
MALAM	1	Brake Head	MAOLJ		<b>BRAKE EXTENSION SCREW</b> (Complete)
MALEN	2	Brake Shoe	MAOMP	23	Brake Extension Screw
MALIP	*3	Brake Head	MAOPH	24	“ “ “ Nut
MALOR	*4	Brake Head	MAORK	25	“ “ “ Jaw
MALUS	*5	Brake Shoe	MAOWF	26	“ “ “ Clevis
MALYT	6	Brake Head Shoe Pin	MAOYI		<b>BRAKE SPREADER CAM</b> (Complete)
MAMAN	7	Brake Head Pin	MAOZY	27	Brake Spreader Cam
MAMEP	*8	Brake Shoe (For Plain Tires)	MAPAR	28	“ “ “ Nut
MAMIR	9	Brake Hanger	MAPES	29	“ “ “ Screw
MAMOS	*10	Brake Hanger	MAPIT		<b>BRAKE SPREADER</b> (Complete)
MAMUT	11	Brake Hanger	MAPOV	30	Brake Extension Nut
MAMYU	12	Brake Head Spring	MAPUW	31	“ “ Swivel
MANAP	13	Brake Head Spring Washer	MAPYZ	*32	<b>Brake Cylinder Bell Crank</b>
MANER	14	Brake Head Spring Eyebolt Stud	MARAS	*33	<b>Brake Shaft Arm</b>
MANIS	15	Brake Head Spring Eyebolt	MARET	*34	<b>Brake Short Lever and Shaft</b>
MANOT	16	Brake Head Spring Pocket	MARIV	*35	<b>Brake Shaft Box</b>
MANUV	17	Brake Head Spring Tap Bolt			
MANYX	18	Brake Head Spring Adjusting Screw			
MAOCT	19	Brake Head Spring			
MAODS	20	Brake Hanger			
MAOGZ	21	Brake Spreader Tee			
MAOHD	22	Brake Spreader Tee			

\*Specify whether for **RIGHT** or **LEFT** side of engine.

Specify **BUILDER'S** locomotive **NUMBER** and **CODE WORD** with each order.





PLATE 5

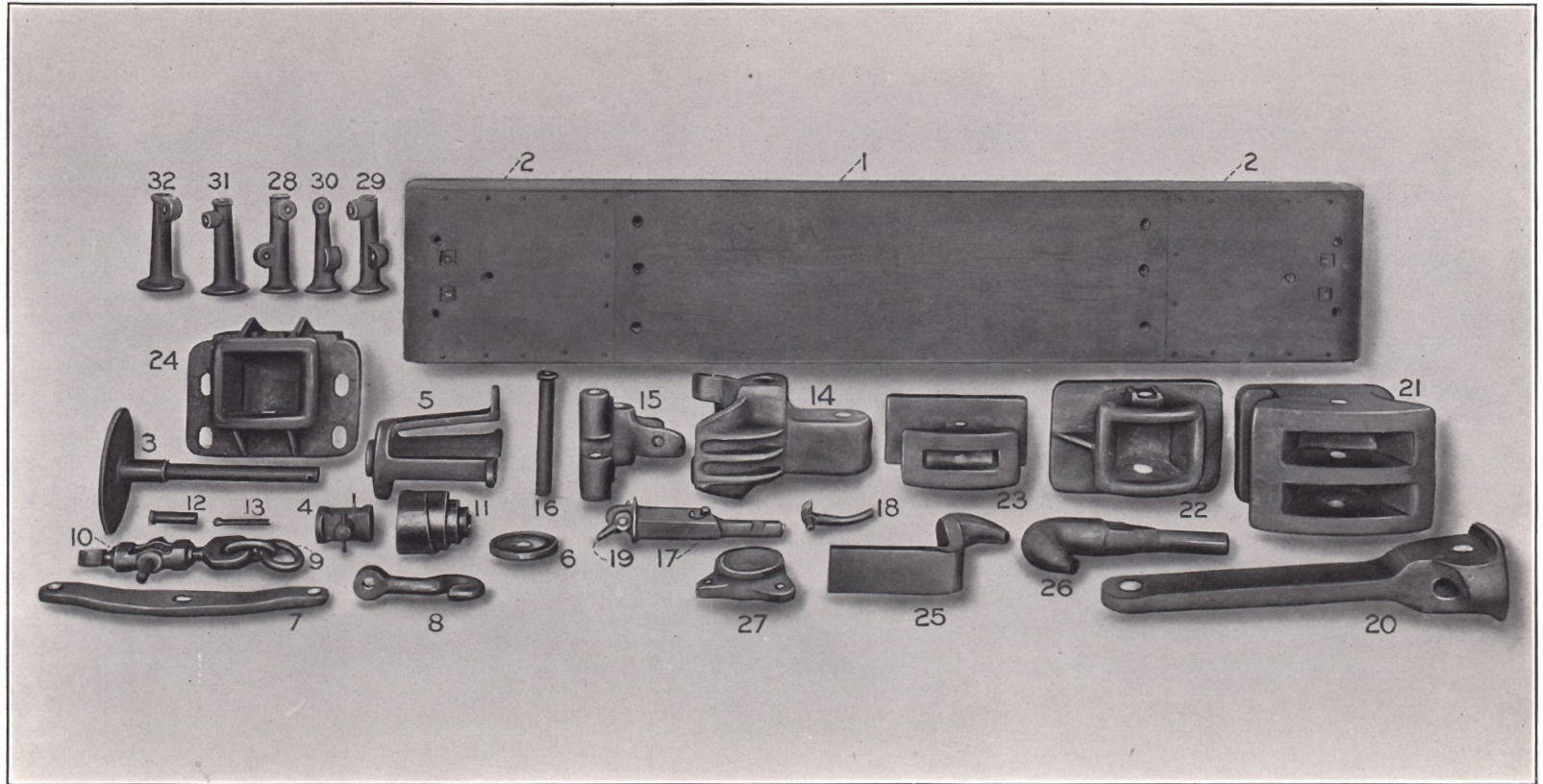



## BUMPER AND DRAFT RIGGING

## PLATE 5

CODE WORD	No.	NAME OF PART	CODE WORD	No.	NAME OF PART
MARLA	1	<b>Bumper</b>	MAVAW	20	<b>Drawbar</b>
MARME	2	<b>Bumper Sheet</b> (One at each end of Bumper)	MAVEX	21	<b>Drawhead</b>
MARNI		<b>BUFFER AND DRAWGEAR</b> (Complete) (Not used in United States)	MAVIY	22	<b>Drawhead</b>
MAROW	3	Buffer Plate	MAVOZ	23	<b>Drawhead</b>
MARRO	4	“ “ Pivot	MAVTI	24	<b>Drawhead</b>
MARSU	5	“ Spring Pocket	MAVWO	25	<b>Drawhook</b>
MARUX	6	“ “ Washer	MAVXU	26	<b>Drawhook</b>
MASAT	7	Coupler Equalizer	MECAC	27	<b>Pushpole Pocket</b>
MASEV	8	“ Hook	MECBI	28	<b>Uncoupling Rigging Column (Right)</b>
MASIW	9	Set of Coupling Links	MECCO	29	<b>Uncoupling Rigging Column (Left)</b>
MASOX	10	Coupling Turnbuckle with Handle (Complete)	MECDU	30	<b>Uncoupling Rigging Column (Middle)</b>
MASTA	11	“ Spring	MECED	31	<b>Handrail Column</b>
MASWE	12	Equalizer Pin	MECFY	32	<b>Handrail Column</b>
MASXI	13	Buffer Plate Cotter			
MATAV		<b>COUPLER</b> (Complete) (M. C. B. Type)			
MATEW	14	Coupler Head			
MATIX	15	“ Knuckle			
MAToy	16	“ Knuckle Pin			
MATTE	17	“ Locking Pin			
MATWI	18	“ Knuckle Opener			
MATXO	19	“ Locking Pin Clevis			

Specify whether **FRONT** or **BACK**.

Specify **BUILDER'S** locomotive **NUMBER** and **CODE WORD** with each order.



PLATE 6

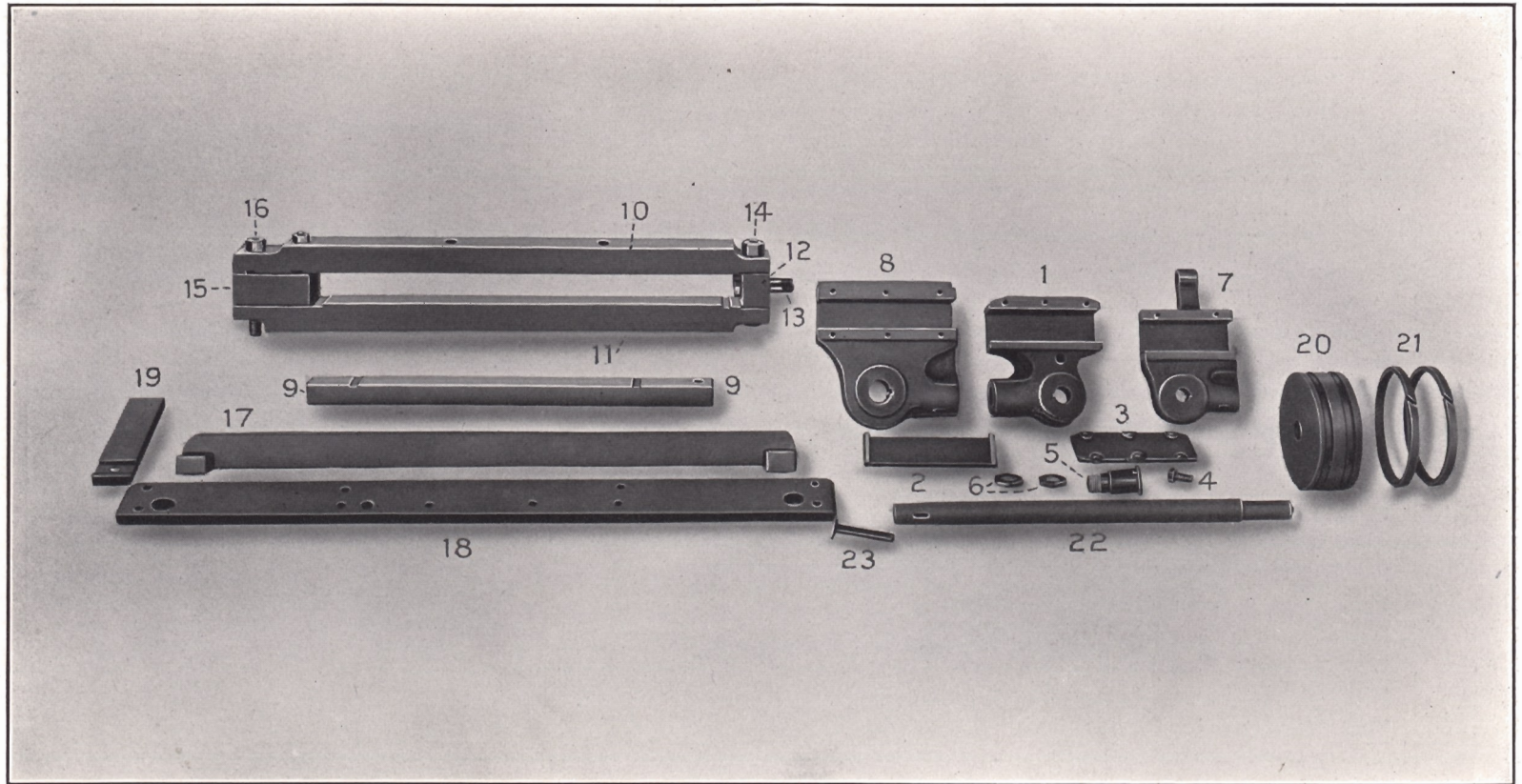

## CROSSHEADS AND GUIDES

## PLATE 6

CODE WORD	No.	NAME OF PART	CODE WORD	No.	NAME OF PART
MECGA	*	<b>CROSSHEAD</b> (Without Pump Lug) (Complete)			<b>CROSSHEAD</b> (Laird Type) (Continued)
MECIF	*1	Crosshead Body	MEDAD	6	Crosshead Pin Nut
MECOG	2	" Gib	MEERD	23	" Key
MECUH	3	" Plate	MEDFA	9	<b>Guide</b>
MECVE	4	" " Tap Bolt	MEDGE		<b>LAIRD GUIDE</b> (Complete)
MECYK	5	" Pin	MEDIG	10	Guide Bar (Upper)
MEDAD	6	" " Nut	MEDOH	11	" " (Lower)
MEERD	23	" Key	MEDUJ	12	" Block (Back)
MEDBO	*	<b>CROSSHEAD</b> (With Pump Lug) (Complete)	MEDVI	13	" " Bolt
MEDCU	*7	Crosshead Body	MEDYL	14	" Bolt (Rear)
MECOG	2	" Gib	MEEBE	15	" Block (Front)
MECUH	3	" Plate	MEECI	16	" Bolt (Front)
MECVE	4	" " Tap Bolt	MEEDO	17	<b>Guide Yoke</b>
MECYK	5	" Pin	MEEFU	18	<b>Guide Yoke</b>
MEDAD	6	" " Nut	MEEGY	19	<b>Guide Yoke End</b>
MEERD	23	" Key	MEEHZ		<b>PISTON AND ROD</b> (Complete)
MEDDY	*	<b>CROSSHEAD</b> (Laird Type) (Complete)	MEEKS	20	Piston Head
MEDEF	*8	Crosshead Body	MEELC	21	" Ring
MECOG	2	" Gib	MEENT	22	" Rod
MECUH	3	" Plate	MEERD	23	Crosshead Key
MECVE	4	" " Tap Bolt			
MECYK	5	" Pin			

\*Specify whether for **RIGHT** or **LEFT** side of locomotive.

Specify **BUILDER'S** locomotive **NUMBER** and **CODE WORD** with each order.



PLATE 7

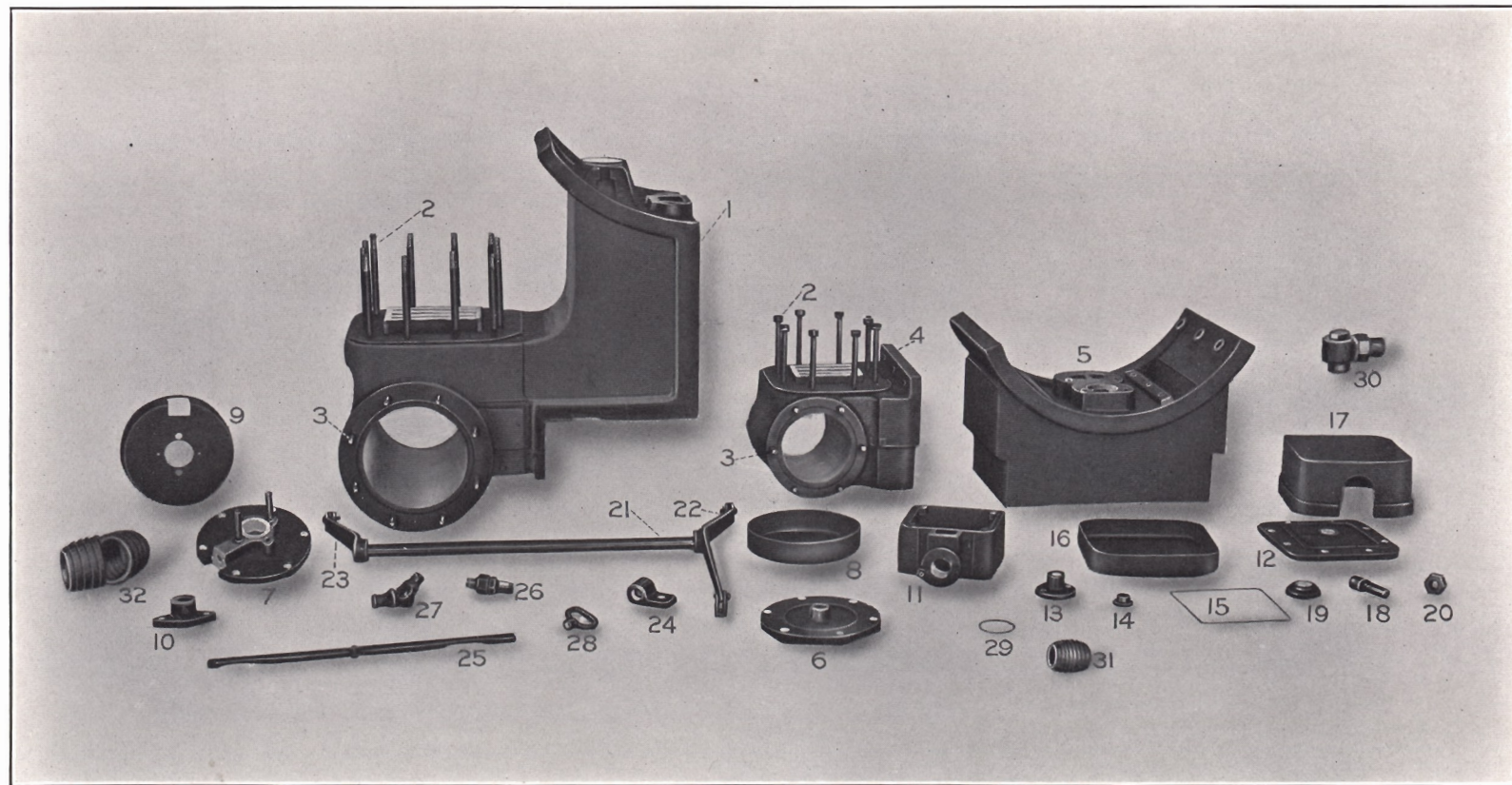



## CYLINDERS

## PLATE 7

CODE WORD	No.	NAME OF PART	CODE WORD	No.	NAME OF PART
MEESP	*1	Cylinder (Half-Saddle Type)	MEGGO	23	Cylinder Cock Shaft Arm
MEETH	2	Steam Chest Stud	MEGIJ	24	Cylinder Cock Shaft Bearing
MEEWG	3	Cylinder Head Stud	MEGOK	25	Cylinder Cock Wedge and Lever
MEEYA	*4	Cylinder (Separate Saddle Type)	MEGUL	26	Cylinder Cock (Straight)
MEFAF	5	Cylinder Saddle	MEGVU	27	Cylinder Cock (Angle)
MEFBU	6	Cylinder Head (Front)	MEGYN	28	Cylinder Cock Rod Handle
MEFCY	7	Cylinder Head (Back)	MEHAH	29	Cylinder-Saddle Copper Joint (For Separate Saddle Type)
MEFDA	8	Cylinder Head Casing (Front) (Pressed Steel)	MEHBA	30	Steam Chest Relief Valve
MEFEG	9	Cylinder Head Casing (Back) (Pressed Steel)	MEHCE	31	Valve Stem Metallic Packing
MEFFE	10	Piston Rod Gland	MEHDI	32	Piston Rod Metallic Packing
MEFGI	11	Steam Chest			
MEFIH	12	Steam Chest Cover			
MEFOJ	13	Valve Stem Gland			
MEFUK	14	Valve Stem Gland Ring (Brass)			
MEFYO	15	Steam Chest Copper Joint			
MEFZM	16	Steam Chest Casing (Top) (Pressed Steel)			
MEGAG	17	Steam Chest Casing (Bottom)			
MEGBY	18	Steam Chest Oiler (Brass)			
MEGCA	19	Steam Chest Oiler Washer			
MEGDE	20	Steam Chest Oiler Nut			
MEGEG	21	Cylinder Cock Shaft			
MEGFI	22	Cylinder Cock Shaft Lever			

\*Specify whether for **RIGHT** or **LEFT** side of locomotive.

Specify **BUILDER'S** locomotive **NUMBER** and **CODE WORD** with each order.

NOTE.—For **SLIDE VALVES** and **VALVE MOTION** see **PLATE 34**.



PLATE 8

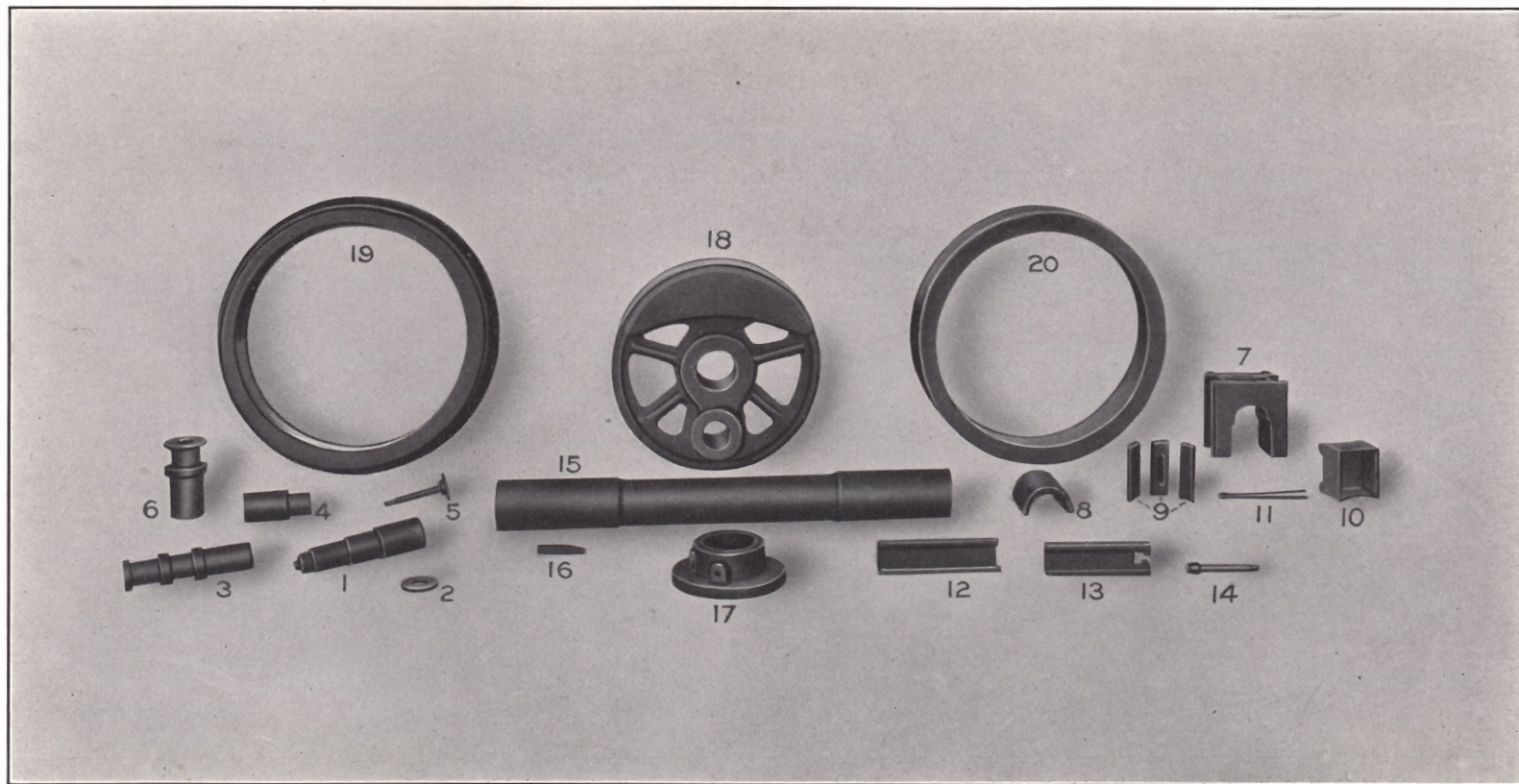



**DRIVING WHEELS AND DETAILS**

**PLATE 8**

CODE WORD	No.	NAME OF PART	CODE WORD	No.	NAME OF PART
MEHEJ	1	<b>Crankpin and Nuts, Main</b> (For Solid End Rods)	MEIWB	†	<b>TWO DRIVING WHEELS</b> (Complete with tires, crankpins, wheels on axle, and axle collars if used)
MEHFO	2	<b>Crankpin Collar</b>	MEIXT		<b>Two Driving Wheels</b> (Complete with tires, crankpins, wheels on axle, eccentrics and eccentric straps)
MEHGU	3	<b>Crankpin, Main</b> (For Strap End Rods)	MEIYE	†15	<b>Driving Wheel Axle</b>
MEHIK	4	<b>Crankpin, Short</b> (Solid End Rods)	MEJAJ	16	<b>Driving Wheel Axle Key</b>
MEHOL	5	<b>Crankpin Collar and Bolt</b>	MEJBE	17	<b>Driving Wheel Axle Collar</b>
MEHUM	6	<b>Crankpin, Short</b> (Strap End Rods)	MEJCI	†18	<b>Driving Wheel Center</b>
MEHVY	*†	<b>DRIVING BOX</b> (Complete)	MEJDO	19	<b>Driving Wheel Tire</b> (Flanged)
MEHYO	*†7	Driving Box	MEJEK	20	<b>Driving Wheel Tire</b> (Plain)
MEIBZ	8	“ “ Brass (Solid)			
MEICS	9	“ “ “ (Three Pieces)			
MEIGN	10	“ “ Cellar			
MEIHC	11	“ “ “ Latch or Cotter			
MEILD	12	<b>Driving Box Shoe</b>			
MEIRF	13	<b>Driving Box Wedge</b>			
MEISH	14	<b>Driving Box Wedge Bolt</b>			

\*Specify whether **RIGHT** or **LEFT**.

†Specify whether **FRONT**, **INTERMEDIATE**, **MAIN** or **REAR**.

Specify **BUILDER'S** locomotive **NUMBER** and **CODE WORD** with each order.





PLATE 9

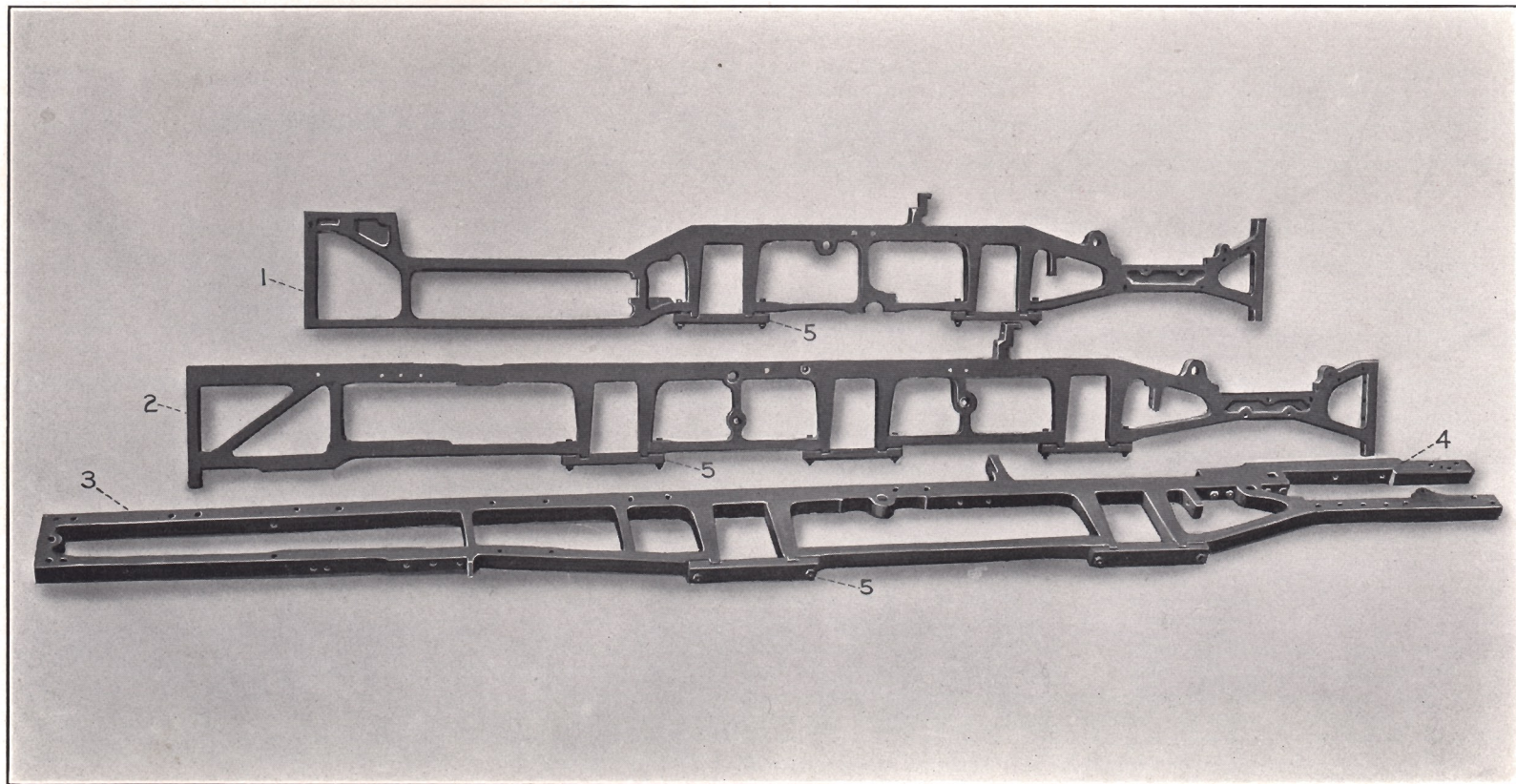



## FRAMES

## PLATE 9

CODE WORD	No.	NAME OF PART	CODE WORD	No.	NAME OF PART
MEJFU	*1	Frame (Four Driver)			
MEJKA	*2	Frame (Six Driver)			
MEJLE	*3	Frame (Four Driver)			
MEKAK	4	Frame Top Rail			
MEKEL	5	Frame Pedestal Brace			

\*Specify whether for **RIGHT** or **LEFT** side of locomotive.

Specify **BUILDER'S** locomotive **NUMBER** and **CODE WORD** with each order.



PLATE 10

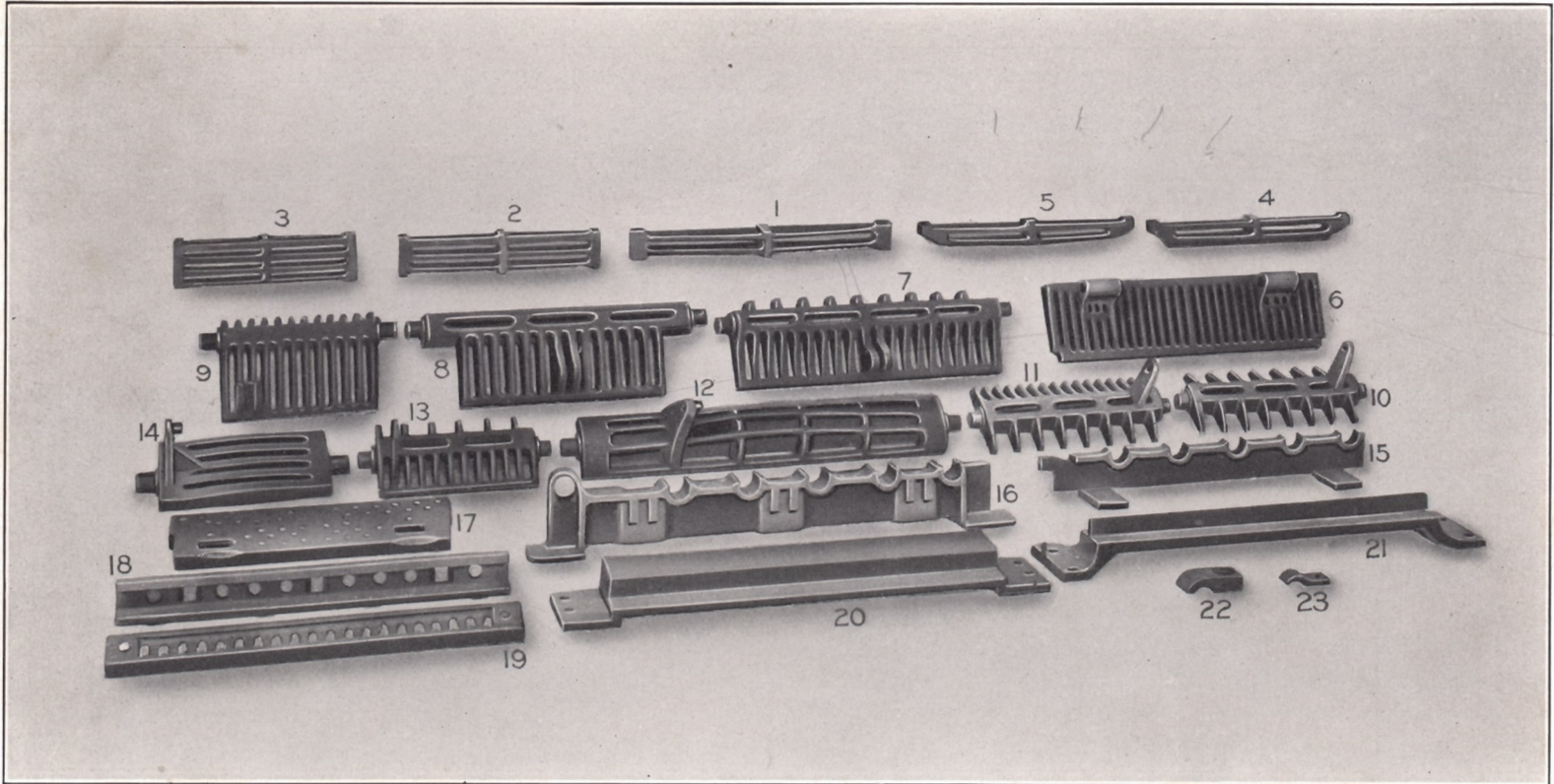



**GRATE DETAILS**

**PLATE 10**

CODE WORD	No.	NAME OF PART	CODE WORD	No.	NAME OF PART
MEKIM	1	Two Bar Grate Bar	MEMIP	17	Drop Grate
MEKON	2	Three Bar Grate Bar	MEMLI	18	Dead Grate
MEKUP	3	Four Bar Grate Bar	MEMMO	19	Dead Grate
MEKYR	4	Two Bar Grate Bar (With Side Strip)	MEMNU	20	Plain Grate Bearing Bar
MELAL	5	Two Bar Grate Bar (Plain)	MEMOR	21	Plain Grate Middle Bearing Bar
MELEM	6	Drop Grate	MEMPY	22	Drop Grate Cap
MELIN	7	Drop Grate	MEMSA	23	Drop Grate Cap
MELLE	8	Drop Grate			
MELMI	9	Drop Grate			
MELNO	10	Rocker Grate			
MELOP	11	Rocker End Grate			
MELPU	12	Rocker Grate			
MELRY	13	Rocker End Grate			
MELUR	14	Rocker Grate			
MEMAM	15	Rocker Grate Bearing Bar			
MEMEN	16	Rocker Grate Bearing Bar			

Specify whether **FRONT** or **BACK**.

Specify whether **RIGHT** or **LEFT**.

Specify **BUILDER'S** locomotive **NUMBER** and **CODE WORD** with each order.



PLATE 11

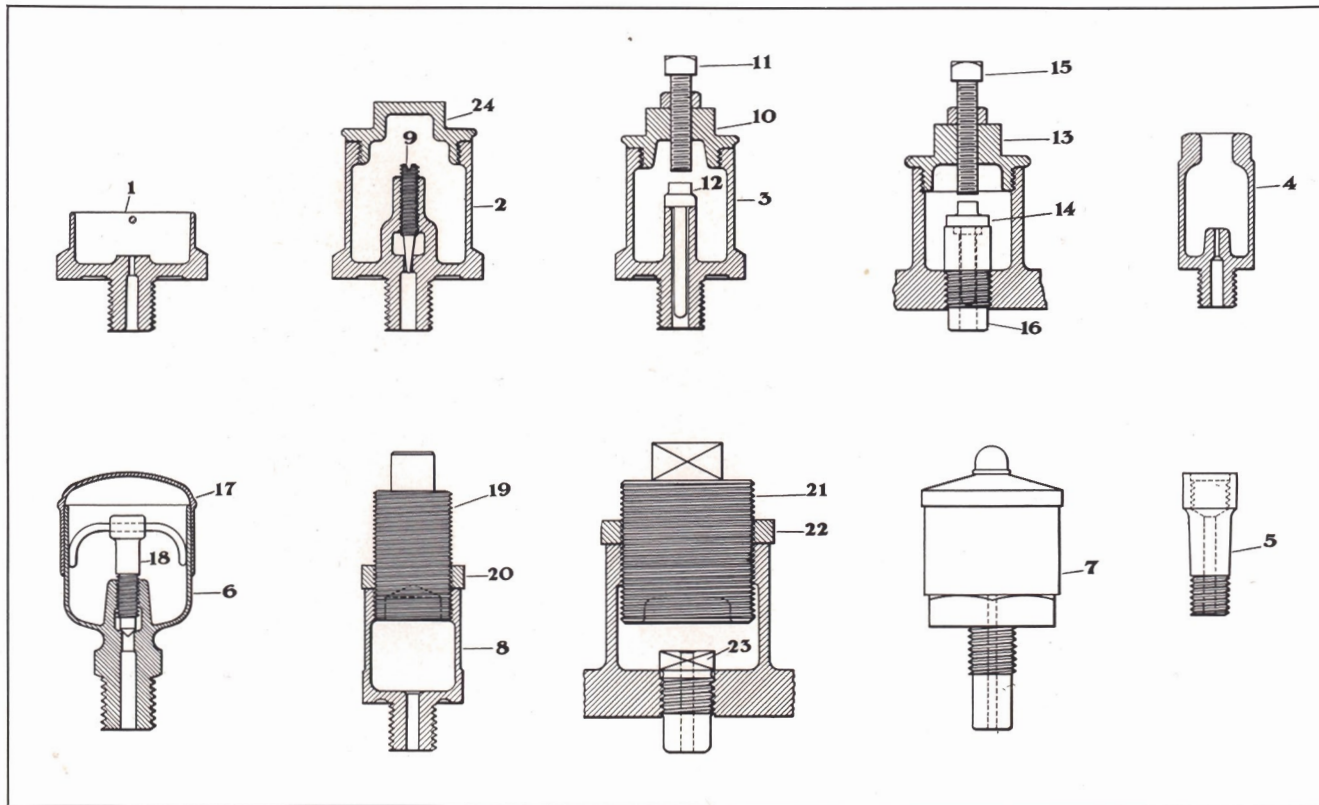



**GREASE AND OIL CUPS**

**PLATE 11**

CODE WORD	No.	NAME OF PART	CODE WORD	No.	NAME OF PART
MEMUS	1	<b>Oil Cup No. 1 for Main Rod</b>	MENOT		<b>OIL CUP NO. 6 (Complete) FOR CROSSHEAD AND GUIDES</b>
MENAN		<b>OIL CUP NO. 2 (Complete) FOR RODS AND CROSS-HEADS</b>	MENRE	6	Oil Cup Body
MENER	2	Oil Cup Body	MERUW	17	“ “ Cap
MERAR	24	“ “ Cap	MESAS	18	“ “ Regulating Screw
MERES	9	“ “ Regulating Screw	MENSI	7	<b>Powell Grease Cup (Complete) for Rods</b>
MENIS		<b>OIL CUP NO. 3 (Complete) FOR RODS</b>	MENUV		<b>GREASE CUP NO. 8 (Complete) FOR RODS</b>
MENLU	3	Oil Cup Body	MEPER	8	Grease Cup Body
MERIT	10	“ “ Cap	MESET	19	“ “ Plug
MERLY	11	“ “ Regulating Screw	MESIV	20	“ “ “ Lock Nut
MERMA	12	“ “ Plunger	MESLA	21	<b>Grease Cup Plug (For Forged on Rod Grease Cup)</b>
MERNE	13	<b>Oil Cup Cap (For Forged on Rod Oil Cup)</b>	MESME	22	<b>Grease Cup Plug Lock Nut (For Forged on Rod Grease Cup)</b>
MEROV	14	<b>Oil Cup Plunger (For Forged on Rod Oil Cup)</b>	MESNI	23	<b>Grease Cup Stud (For Forged on Rod Grease Cup)</b>
MERRI	15	<b>Oil Cup Regulating Screw (For Forged on Rod Oil Cup)</b>			
MERSO	16	<b>Oil Cup Stud (For Forged on Rod Oil Cup)</b>			
MENMY	4	<b>Oil Cup No. 4 for Rocker Boxes</b>			
MENNA	5	<b>Oil Cup Extension for Rocker Boxes</b>			

Specify **BUILDER'S** locomotive **NUMBER** and **CODE WORD** with each order.



PLATE 12

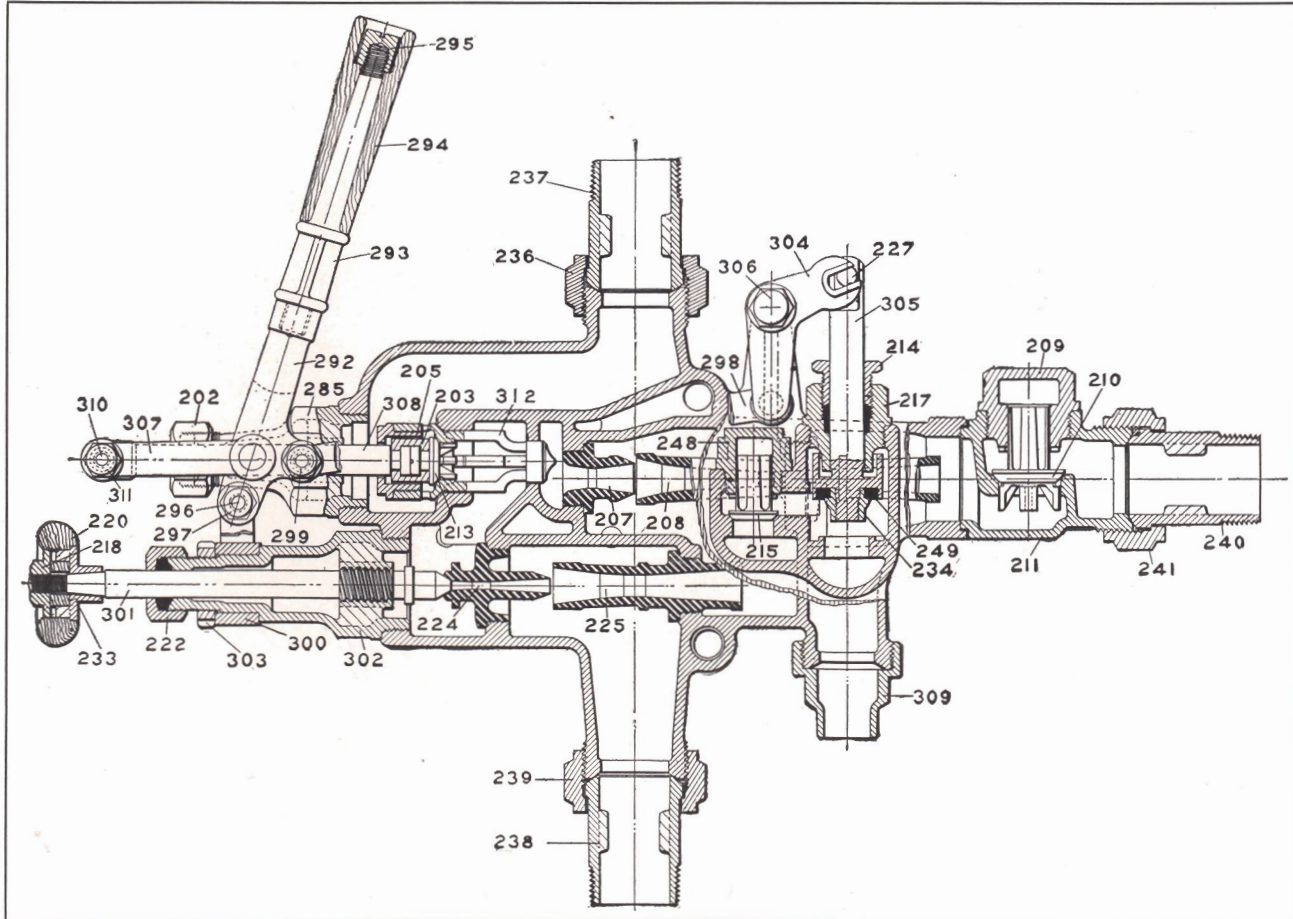



**METROPOLITAN INJECTORS**

**PLATE 12**

CODE WORD	No.	NAME OF PART	CODE WORD	No.	NAME OF PART
MESOW		<b>INJECTOR (Complete)</b>			<b>INJECTOR (Continued)</b>
MESRO	202	Packing Nut for 285	MIDDU	248	Overflow Valve Cap
MESSU	203	Clamp Ring	MIDED	249	Disc for Overflow Valve
MESUX	205	Steam Swivel Ring	MIDFY	285	Steam Center Piece
METAT	207	Forcing Steam Jet	MIDGA	289	Overflow Valve Crank Bolt Nut
METEV	208	Forcing Combining Tube	MIDIF	292	Lever
METIW	209	Check Valve Cap	MIDOG	293	Handle Rod
METOX	210	Check Valve	MIDUH	294	Wood Handle
METTA	211	Check Valve Casing	MIDVE	295	Handle Nut
METWE	213	Auxiliary Steam Valve	MIDYK	296	Fulcrum Bolt
METXI	214	Packing Gland for 305	MIFAD	297	Nut for Fulcrum Bolt
MEVAV	215	Overflow Valve	MIFBO	298	Connecting Bar
MEVEW	217	Overflow Center Piece	MIFCU	299	Nut for Connecting Bar
MEVIX	218	Regulating Valve Handle Nut	MIFDY	300	Fulcrum Collar
MEVOY	220	Regulating Valve Wheel	MIFEV	301	Regulating Steam Stem
MEVTE	222	Packing Nut for 302	MIFFA	302	Regulating Center Piece
MEVWI	224	Lifting Steam Jet	MIFGE	303	Fulcrum Nut
MEVXO	225	Lifting Combining Tube	MIFIG	304	Overflow Valve Crank
MEWAW	227	Overflow Valve Pin	MIFOH	305	Overflow Valve Stem
MEWEX	231	Stud Bolts	MIFUJ	306	Overflow Valve Crank Bolt
MEWIY	233	Regulating Valve Wheel Disc	MIFVI	307	Side Links
MEWOZ	234	Nut for Overflow Disc	MIFYL	308	Steam Valve Stem
MEWTI	236	Union Nut Steam End	MIGAF	309	Overflow Nozzle
MEWWO	237	Tail Pipe Steam End	MIGBU	310	Bolt for Side Link
MEWXU	238	Tail Pipe Suction End	MIGCY	311	Nut for Side Link Bolt
MEXAX	239	Union Nut Suction End	MIGDA	312	Steam Valve
MIDAC	240	Tail Pipe Delivery End	MIGEG		Tube Wrench
MIDBI	241	Union Nut Delivery End	MIGFE	247	Coupling for Overflow Connection
MIDCO	245	Nuts for 231	MIGGI	250	Tail Pipe for Overflow Connection

Always state the **SIZE NUMBER** of the injector, the **MODEL LETTER**, and give the **FACTORY** or **SERIAL NUMBER**.





PLATE 13

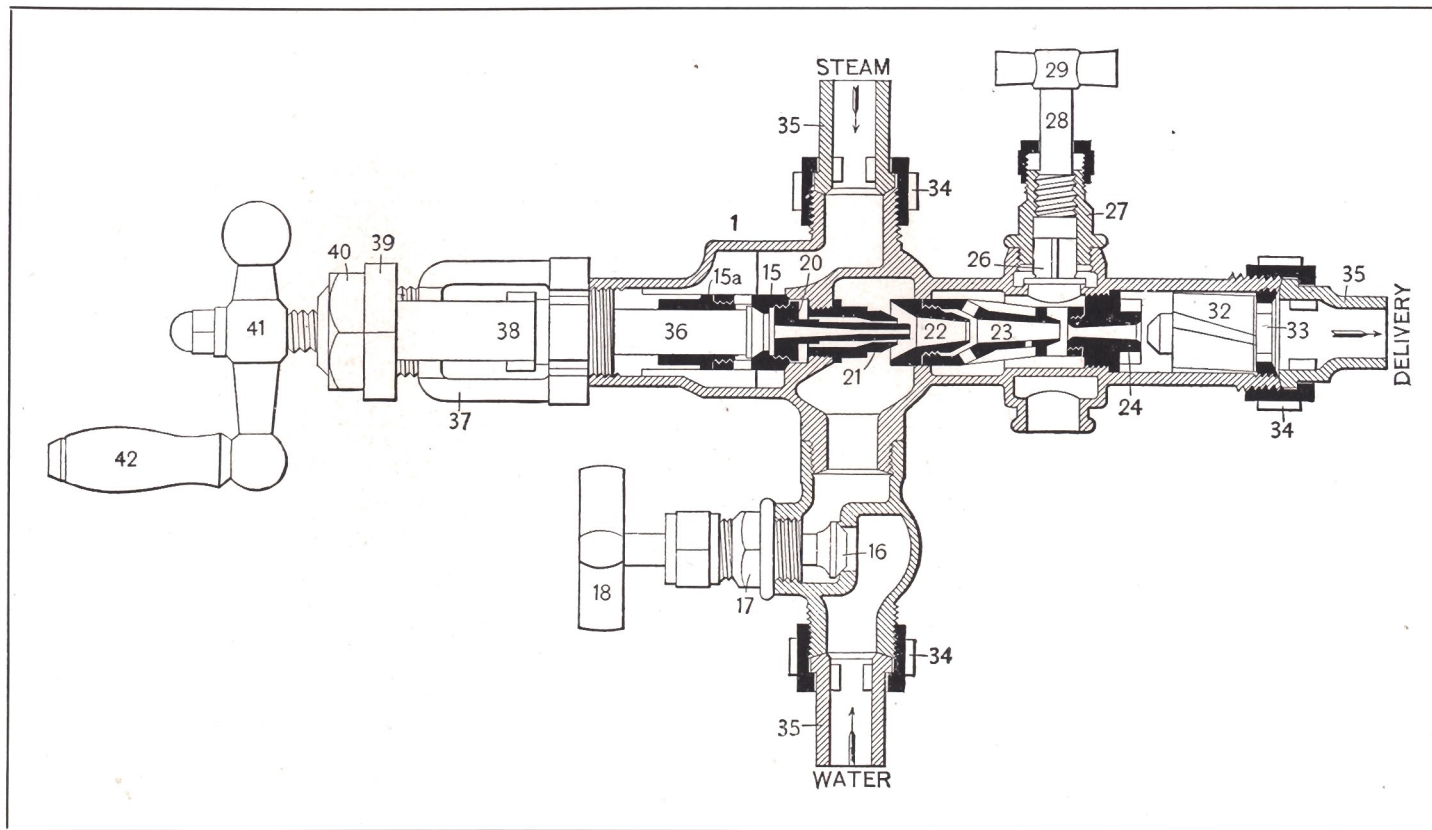



**MONITOR INJECTORS. Nos. 2 and 3**

**PLATE 13**

CODE WORD	No.	NAME OF PART	CODE WORD	No.	NAME OF PART
MIGIH		<b>INJECTOR</b> (Complete)			<b>INJECTOR</b> (Continued)
MIGOJ	1	<b>Body</b> (Proper)	MIJFO	38	<b>Yoke Gland</b>
MIGUK	15	<b>Steam Valve</b>	MIJGU	39	<b>Yoke Packing Nut</b>
MIGVO	15a	<b>Steam Valve Lock Nut</b>	MIJIK	40	<b>Yoke Lock Nut</b>
MIGYM	16	<b>Water Valve</b>	MIJOL	41	<b>Steam Valve Handle</b>
MIHAG	17	<b>Water Valve Bonnet and Nut</b>	MIJUM	42	<b>Steam Valve Rubber Handle</b>
MIHBY	18	<b>Water Valve Handle</b>			
MIHCA	20	<b>Lifting Nozzle</b>			
MIHDE	21	<b>Steam Nozzle</b>			
MIHEH	22	<b>Intermediate Nozzle</b>			
MIHFI	23	<b>Condensing Nozzle</b>			
MIHGO	24	<b>Delivery Nozzle</b>			
MIHIJ	26	<b>Heater Cock Check</b>			
MIHOK	27	<b>Heater Cock Bonnet and Nut</b>			
MIHUL	28	<b>Heater Cock Spindle</b>			
MIHVU	29	<b>Heater Cock Handle</b>			
MIHYN	32	<b>Line-check Valve</b>			
MIJAH	33	<b>Stop Ring</b>			
MIJBA	34	<b>Coupling Nut</b> (Steam, water or delivery)			
MIJCE	35	<b>Tail Piece</b> (Steam, water or delivery)			
MIJDI	36	<b>Steam Spindle</b>			
MIJEJ	37	<b>Yoke</b>			

In ordering parts, always state the **SIZE** and **TYPE** of Injector and the **SHOP NUMBER** stamped upon the same, to insure correctness of repair part wanted.



PLATE 14

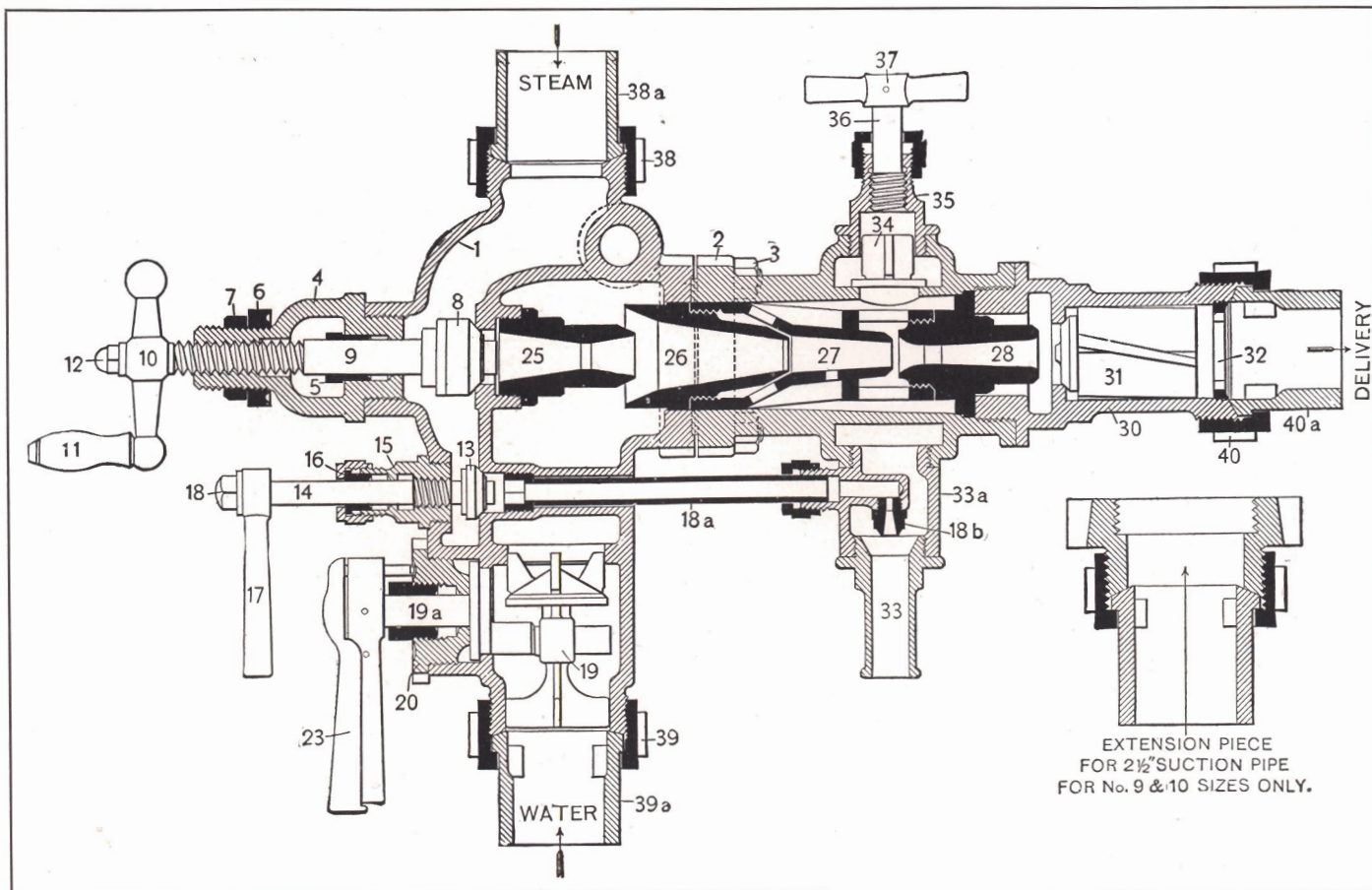



MONITOR INJECTOR. Nos. 4 to 12

PLATE 14

CODE WORD	No.	NAME OF PART	CODE WORD	No.	NAME OF PART
MIJVY		INJECTOR (Complete)	MIMOP	19a	Eccentric Spindle
MIJYO	1	Body Back Part	MIMPU	20	Water Valve Bonnet
MIKAJ	2	Body Front Part	MIMRY	23	Water Valve Handle
MIKBE	3	Body Screw	MIMUR	25	Steam Nozzle
MIKCI	4	Yoke	MINAM	26	Intermediate Nozzle
MIKDO	5	Yoke Gland	MINEN	27	Condensing Nozzle
MIKEK	6	Yoke Packing Nut	MINIP	28	Delivery Nozzle
MIKFU	7	Yoke Lock Nut	MINLI	30	Line Check Casing
MIKKA	8	Steam Valve Disc and Nut	MINMO	31	Line Check Valve
MIKLE	9	Steam Valve Spindle	MINNU	32	Stop Ring
MILAK	10	Steam Valve Handle	MINOR	33	Overflow Nozzle
MILEL	11	Steam Valve Rubber Handle	MINPY	33a	Overflow Chamber and Nut
MILIM	12	Steam Valve Top Nut	MINSA	34	Heater Cock Check
MILON	13	Jet Valve Disc and Nut	MINUS	35	Heater Cock Bonnet and Nut
MILUP	14	Jet Valve Spindle	MIOBZ	36	Heater Cock Spindle
MILYR	15	Jet Valve Bonnet and Nut	MIOCS	37	Heater Cock Handle
MIMAL	16	Jet Valve Gland	MIOGN	38	Coupling Nut (Steam)
MIMEM	17	Jet Valve Handle	MIOHC	39	Coupling Nut (Water)
MIMIN	18	Jet Valve Top Nut	MIOLD	40	Coupling Nut (Delivery)
MIMLE	18a	Jet Valve Tube	MIORF	38a	Tailpiece (Steam)
MIMMI	18b	Lifting Nozzle	MIOSH	39a	Tailpiece (Water)
MIMNO	19	Water Valve	MIOWB	40a	Tailpiece (Delivery)

In ordering repair parts, always state the **SIZE** and **TYPE** of Injector and the **SHOP NUMBER** stamped upon the same, to insure correctness of repair parts wanted.



PLATE 15

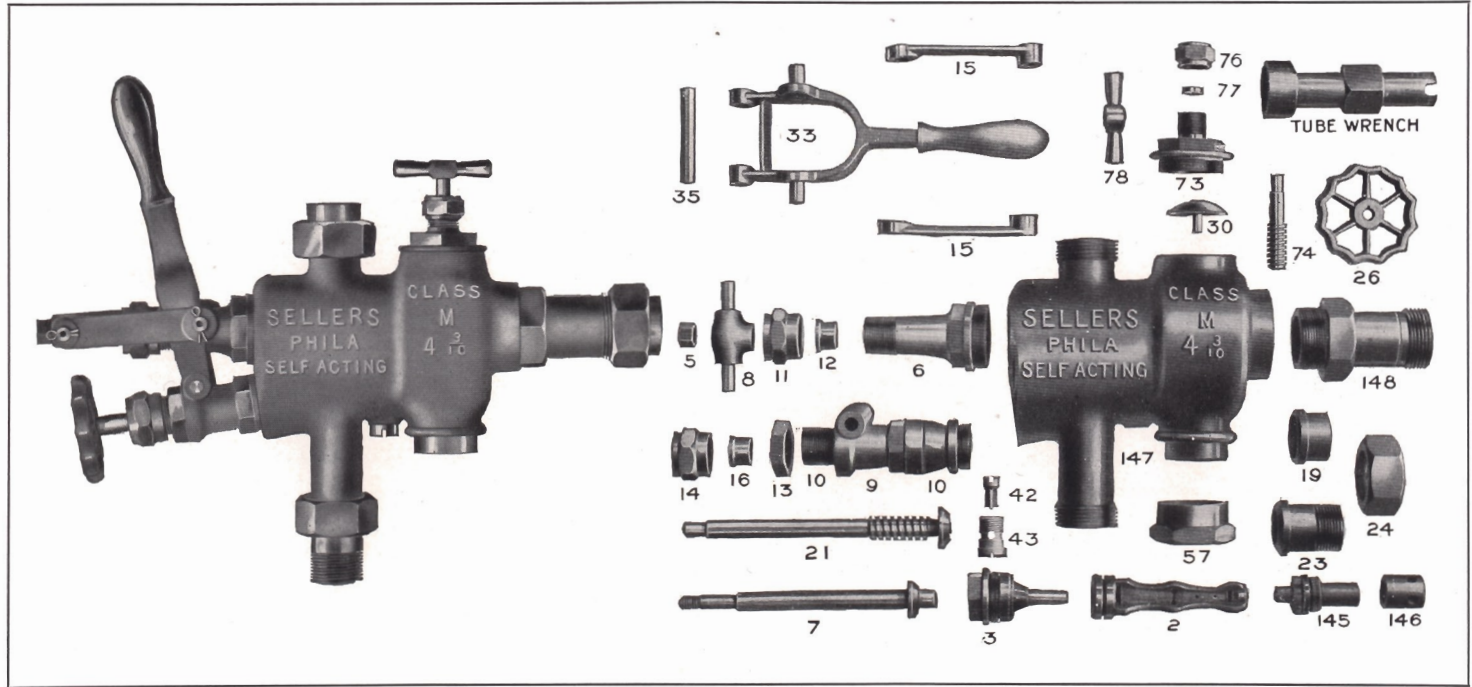



**SELLERS CLASS "M" 4.3 INJECTOR**

**PLATE 15**

<b>CODE WORD</b>	<b>No.</b>	<b>NAME OF PART</b>	<b>CODE WORD</b>	<b>No.</b>	<b>NAME OF PART</b>
MIOTW		<b>INJECTOR</b> (Complete)			<b>INJECTOR</b> (Continued)
MIOXT	2	Combining Tube	MIRUV	35	Pins Nos. 9 and 33
MIOYE	3	Steam Nozzle	MISAR	42	Inlet Valve
MIPAN	5	Spindle Nut	MISES	43	Seat for No. 42
MIPEP	6	Steam Stuffing Box	MISIT	55	Tube Wrench
MIPIR	7	Spindle	MISLY	57	Closed Overflow Connection
MIPLO	8	Crosshead	MISMA	73	Guide for Overflow Valve
MIPMU	9	Collar on No. 10	MISNE	74	Heater Stem
MIPNY	10	Water Stuffing Box	MISOV	76	Follower on No. 73
MIPOS	11	Follower	MISRI	77	Packing Ring in No. 73
MIPRA	12	Packing Ring	MISSO	78	Heater Lever
MIPSE	13	Lock Nut	MISUW	145	Delivery Tube
MIPUT	14	Follower for No. 10	MITAS	146	Check Valve
MIRAP	15	Links	MITET	147	Injector Body
MIRER	16	Packing Ring	METIV	148	Lower Cylinder
MIRIS	19	Ring for Copper Pipe			
MIRLU	21	Valve Stem			
MIRMY	23	Union for Iron Pipe			
MIRNA	24	Coupling Nut			
MIROT	26	Hand Wheel			
MIRRE	30	Waste Valve			
MIRSI	33	Starting Lever			

When ordering repair parts, give the **NAME** and **NUMBER** of part required, the **SIZE**, **CLASS** and **PROGRESSIVE NUMBER** of Injector.



PLATE 16

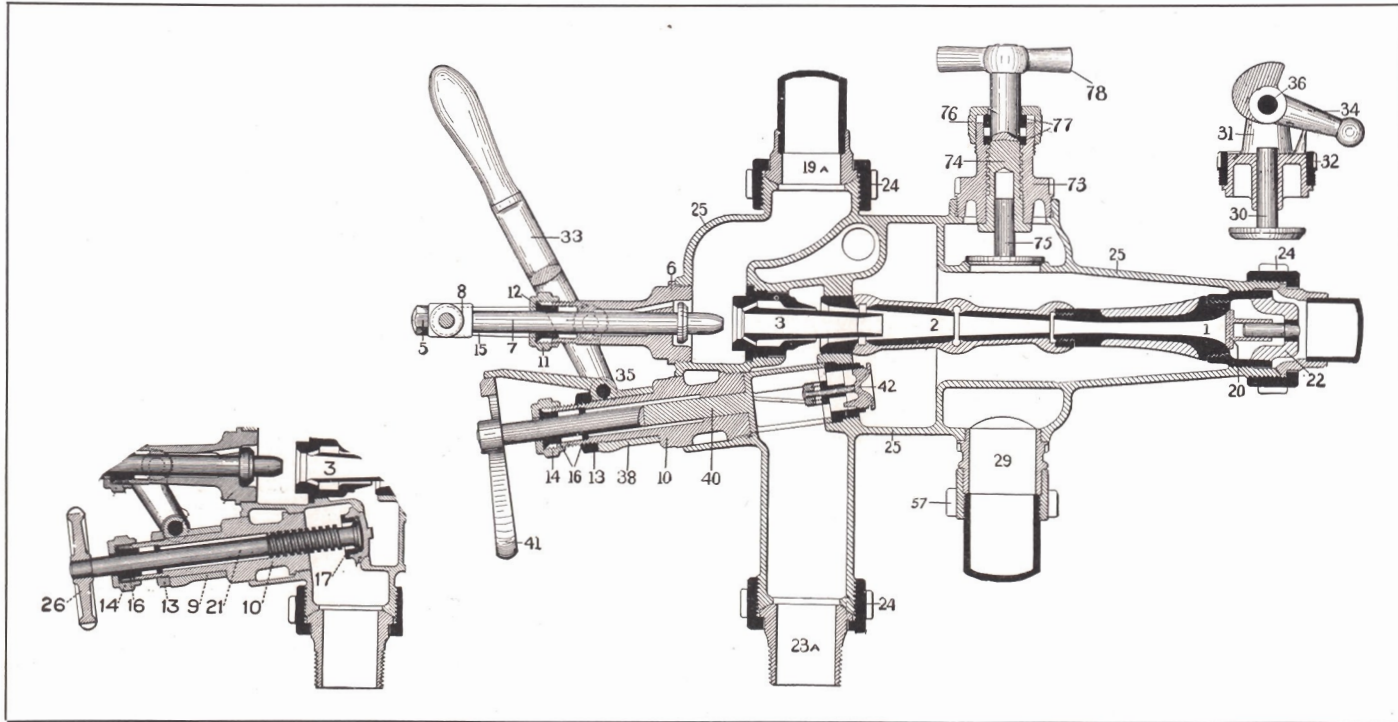



**SELLERS CLASS "M" IMPROVED INJECTOR**

**PLATE 16**

CODE WORD	No.	NAME OF PART	CODE WORD	No.	NAME OF PART
MITJB		<b>INJECTOR (Complete)</b>			<b>INJECTOR (Continued)</b>
MITLA	1	Delivery Tube	MIVTA	23a	Unions for Iron Pipes (Reducing)
MITME	2	Combining Tube	MIVWE	24	Coupling Nuts
MITNI	3	Steam Nozzle	MIVXI	25	Injector Body
MITOW	5	Spindle Nut	MIWAW	26	Hand Wheel on No. 21
MITRO	6	Steam Stuffing Box	MIWEX	27	Wrench for No. 24
MITSU	7	Spindle	MIWIY	29	Waste Pipe
MITUX	8	Crosshead	MIWVA	33	Starting Lever
MIUBS	9	Collar on No. 10	MIWOZ	35	Pin, Nos. 38 and 33
MIUCH	10s	Water Stuffing Box	MIWTI	38	Collar and Index
MIUDZ	10	Water Stuffing Box	MIWVO	39	Funnel
MIUFT	11	Follower	MIWXU	40	Plug Water Valve
MIUGH	12	Packing Ring	MIXAX	41	Regulating Handle
MIUHB	13	Lock Nut	MIXEY	42	Inlet Valve
MIULG	14	Follower for No. 10	MIXIZ	55	Tube Wrench
MIUNK	15	Links	MIYAY	57	Waste Pipe Connection
MIURJ	16	Packing Rings	MIYEZ	73	Guide for Waste Valve
MIUSY	19	Rings for Copper Pipe (Plain)	MIZAY	74	Heater Stem
MIUWC	19a	Rings for Copper Pipe (Reducing)	MOABS	75	Waste Valve
MIVAT	20	Check Valve	MOACH	76	Follower on No. 73
MIVEV	21	Screw Spindle	MOADZ	77	Packing Rings in No. 73
MIVIW	22	Guide for No. 20	MOAFT	78	Heater Lever
MIVOX	23	Unions for Iron Pipes (Plain)			

When ordering repair parts, give the **NAME** and **NUMBER** of part required, the **SIZE**, **CLASS** and **PROGRESSIVE NUMBER** of Injector.





PLATE 17

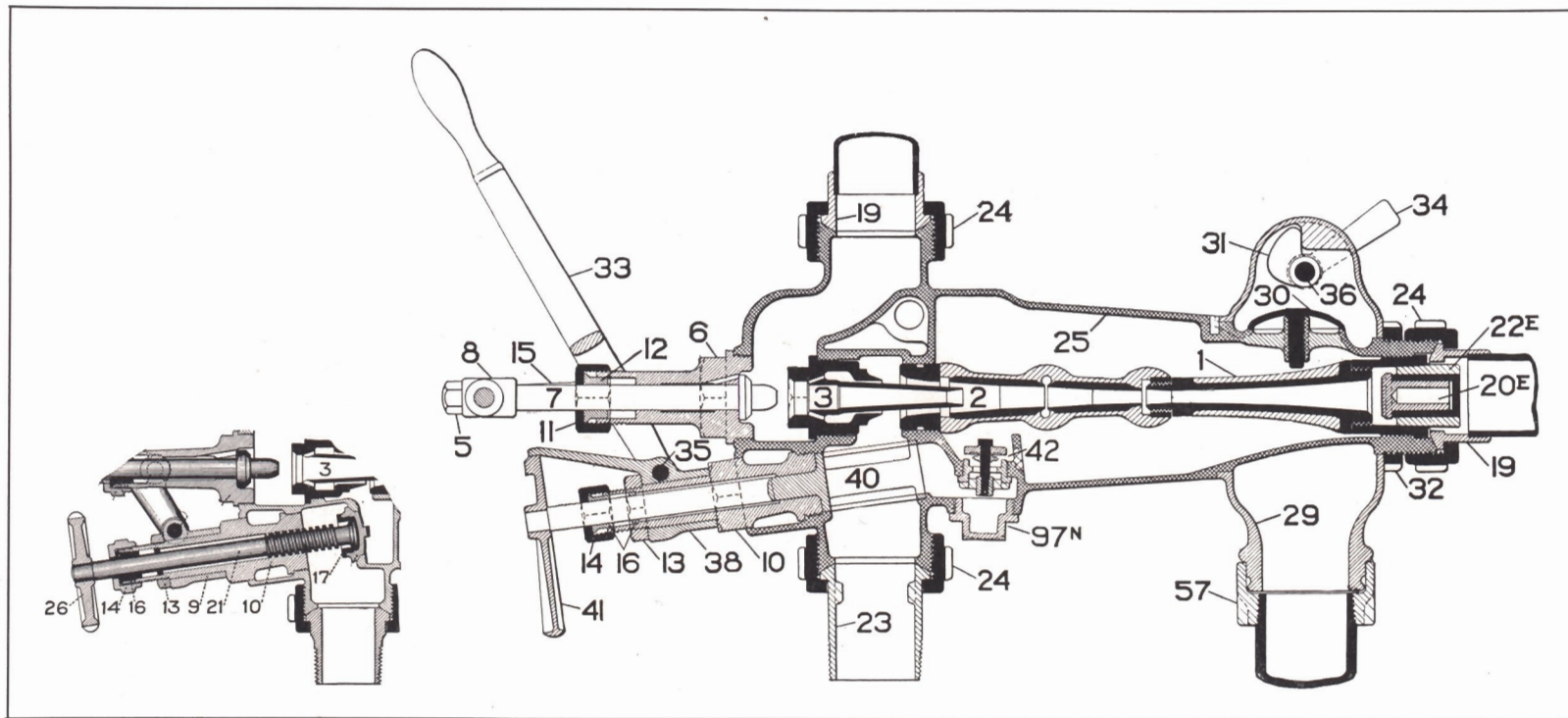



**SELLERS CLASS "N" IMPROVED INJECTOR**

**PLATE 17**

CODE WORD	No.	NAME OF PART	CODE WORD	No.	NAME OF PART
MOAID		<b>INJECTOR (Complete)</b>			<b>INJECTOR (Continued)</b>
MOAGH	1	Delivery Tube	MOGDY	23a	Union for Iron Pipe (Reducing)
MOAHB	2	Combining Tube	MOGEF	24	Coupling Nuts
MOALG	3	Steam Nozzle	MOGFA	25	Injector Body
MOANK	5	Spindle Nut	MOGGE	26	Hand Wheel on No. 21
MOARJ	6	Steam Stuffing Box	MOGIG	27	Wrench for No. 24
MOASY	7	Spindle	MOGOY	29	Waste Pipe
MOAWC	8	Crosshead	MOGUJ	30	Waste Valve
MOFAC	9	Collar on No. 10	MOGVI	31	Waste Valve Cam
MOFBI	10s	Water Stuffing Box	MOGYL	32	Jam Nut for No. 29
MOFCO	10	Water Stuffing Box	MOHAF	33	Starting Lever
MOFDU	11	Follower	MOHBU	34	Cam Lever
MOFED	12	Packing Ring	MOHCY	35	Pin, Nos. 38 and 33
MOFFY	13	Lock Nut	MOHDA	36	Cam Shaft
MOFGA	14	Follower for No. 10	MOHEG	37	Washer on No. 36
MOFIF	15	Links	MOHFE	38	Collar and Index
MOFOG	16	Packing Ring	MOHGI	39	Funnel
MOFUH	19	Rings for Copper Pipe (Plain)	MOHIH	40	Plug Water Valve
MOFVE	19a	Rings for Copper Pipe (Reducing)	MOHOJ	41	Regulating Handle
MOGAD	20e	Check Valve	MOHUK	42	Inlet Valve
MOFYK	21	Screw Spindle	MOHVO	55	Tube Wrench
MOGBO	22e	Guide for No. 20	MOHYM	57	Waste Pipe Connection
MOGCU	23	Union for Iron Pipe (Plain)	MOHZN	97n	Cap under No. 42

When ordering repair parts, give **NAME** and **NUMBER** of part required, the **SIZE**, **CLASS** and **PROGRESSIVE NUMBER** of Injector.



PLATE 18

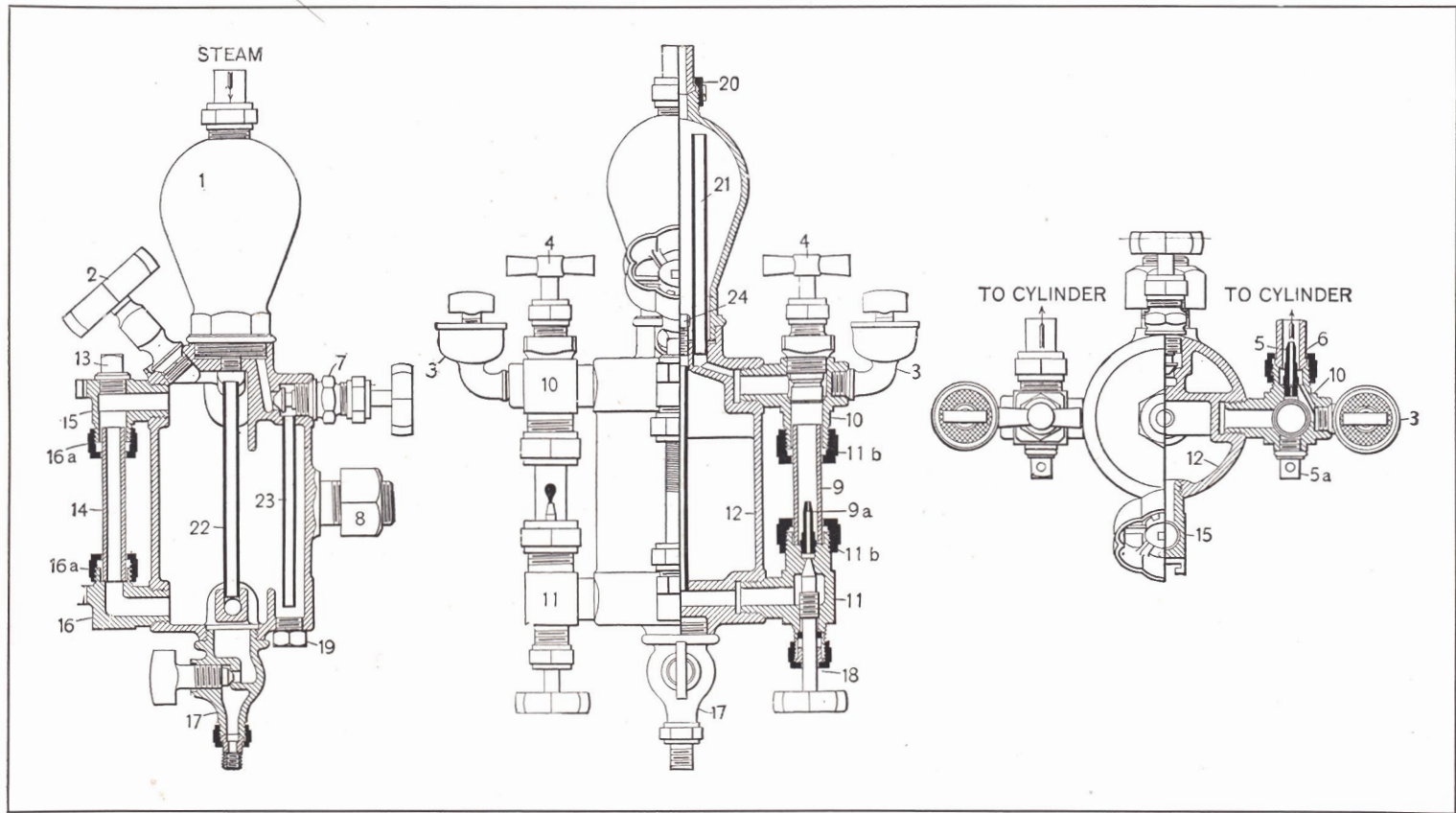



**NATHAN LOCOMOTIVE LUBRICATOR. Old Style Nos. 2 and 3 PLATE 18**

CODE WORD	No.	NAME OF PART	CODE WORD	No.	NAME OF PART
MOJAG		LUBRICATOR (Complete)			LUBRICATOR (Continued)
MOJBY	1	Condenser	MOKVY	18	Regulating Valve
MOJCA	2	Filling Plug	MOKYO	19	Bottom Plug
MOJDE	3	Auxiliary Oiler	MOLAJ	20	Top Connection
MOJEH	4	Safety Valve	MOLBE	21	Equalizing Pipe
MOJFI	5	Reducing Plug	MOLCI	22	Oil Pipe
MOJGO	5a	Blow-off Plug	MOLDO	23	Water Pipe
MOJIJ	6	Delivery Nut and Tail Piece	MOLEK	24	Center Body Plug
MOJOK	7	Water Valve			
MOJUL	8	Stud Nut			
MOJVU	9	Sight Feed Glass			
MOJYN	9a	Feed Nozzle			
MOKAH	10	Upper Sight Bracket			
MOKBA	11	Lower Sight Bracket			
MOKCE	11b	Sight Glass Packing Nut			
MOKDI	12	Body			
MOKEJ	13	Gauge Glass Plug			
MOKFO	14	Gauge Glass			
MOKGU	15	Upper Gauge Bracket			
MOKIK	16	Lower Gauge Bracket			
MOKOL	16a	Gauge Glass Nut			
MOKUM	17	Waste Cock			

Please use above NUMBERS and CODE WORDS in ordering repair parts.



PLATE 19

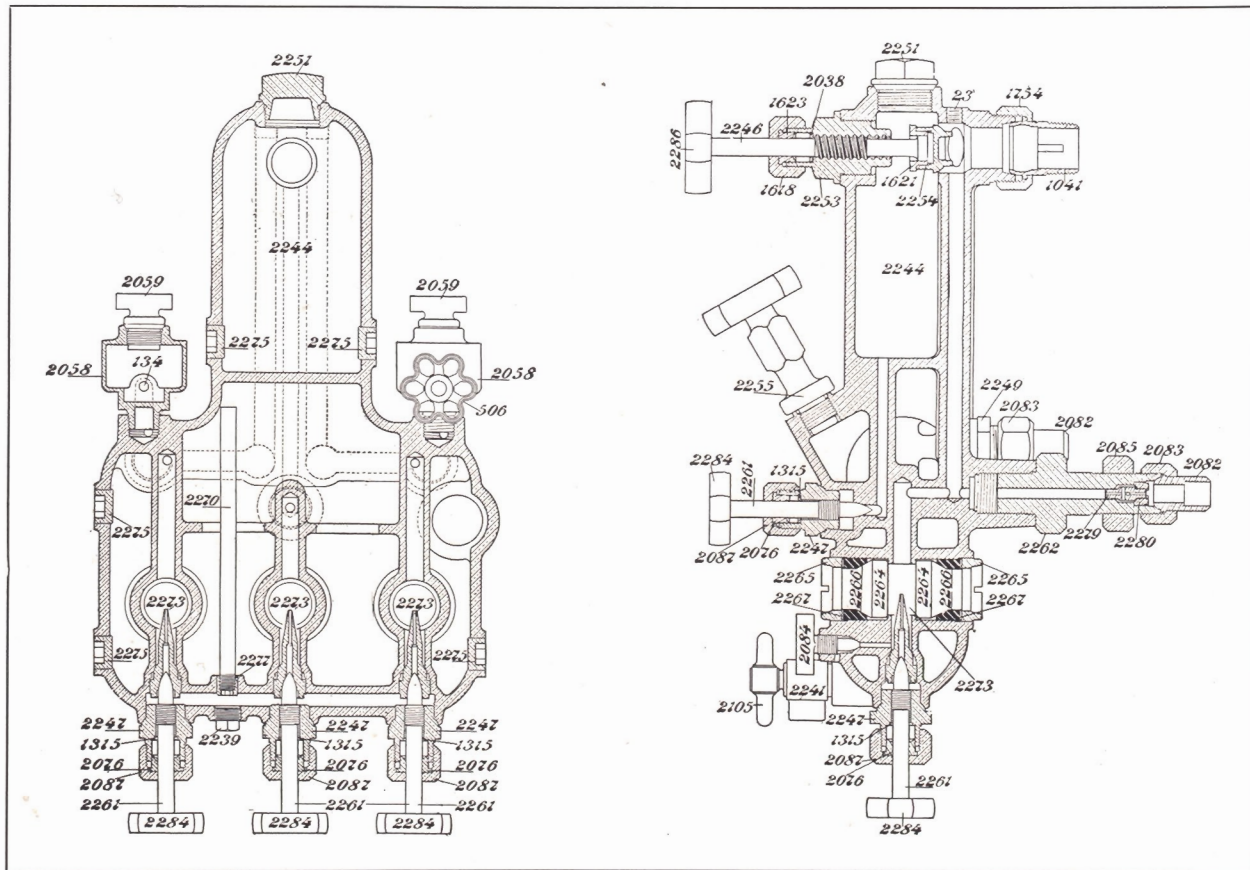



Detroit Locomotive Lubricators. Nos. 0, 5, 7, 11, 21, 31, 41 and 61

PLATE 19

CODE WORD	No.	NAME OF PART	CODE WORD	No.	NAME OF PART
MOLFU		LUBRICATOR (Complete)			LUBRICATOR (Continued)
MOLKA	23	13-32-inch Blind Plug	MOPAM	2253c	Steam Valve Center Piece
MOLLE	57	9-16-inch Blind Plug	MOPEN	2254	Steam Valve Disc
MOMAK	134	Hand Oiler and Water Feed Stem with Handle (Complete)	MOPIP	2255	Filler Plug (Complete)
MOMEL	506	Hand Oiler Valve Handle	MOPLI	2261	Feed Valve Stem
MOMIM	1041	1-inch Tail Pipe	MOPMO	2262	Support Arm
MOMON	1294	Hand Oiler Stem Washer	MOPNU	2264	Sight Feed and Gauge Glass
MOMUP	1315	Feed Stem Ring	MOPOR	2265	Feed Glass Packing Ring
MOMYR	1618a	Steam Valve Packing Nut	MOPPY	2266	Sight Feed and Gauge Glass Rubber Packing
MONAL	1621	Steam Valve Disc Lock Nut	MOPSA	2267	Feed Glass Washer
MONEM	1623	Steam Valve Packing Gland	MOPUS	2270	Oil Tube
MONIN	1754	1-inch Tail Nut	MORAN	2273	Feed Nozzle
MONMI	1953	Water Feed Valve Packing Nut	MOREP	2277	Oil Tube Bushing
MONNO	1957	Water Feed Valve Gland	MORIR	2279	Air Pump Choke
MONOP	2038	Steam Valve Packing Ring	MORLO	2280	Air Pump Choke Seat
MONPU	2044	5-16-inch Brass Ball	MORMU	2284	Regulating Valve Handle
MONRY	2058	Hand Oiler Body	MORNY	2286	Steam Valve Handle
MONXE	2059	Hand Oiler Filler Plug	MOROS	2297	7-8-inch Plug
MOOBE	2076	Feed Stem Packing Gland	MORRA	2329	Hand Oiler Center Piece
MOOCI	2082	Tail Pipe	MORSE		Feed Valve Packing
MOODU	2083	Tail Nut	MORUT		Steam Valve Packing
MOOFU	2084	Vent Stem	MORVX		Hand Oiler Packing
MOOGY	2085	Support Arm Jam Nut			
MOOHZ	2087a	Feed Valve Stem Nut			
MOOKS	2105	Drain Stem			
MOOLC	2238	Water Check Stop			
MOONT	2239	11-16-inch Plug			
MOORD	2241	Drain Valve Body			
MOOSP	2246	Steam Valve Stem			
MOUTH	2247a	Feed Valve Center Piece			
MOOWG	2249	Tail Pipe Center Piece			
MOOYA	2251	Condenser Plug			

Be sure to give the part NUMBER, NAME OF PART and the SERIAL NUMBER of the Lubricator which is stamped on the name plate on the condenser.



PLATE 20

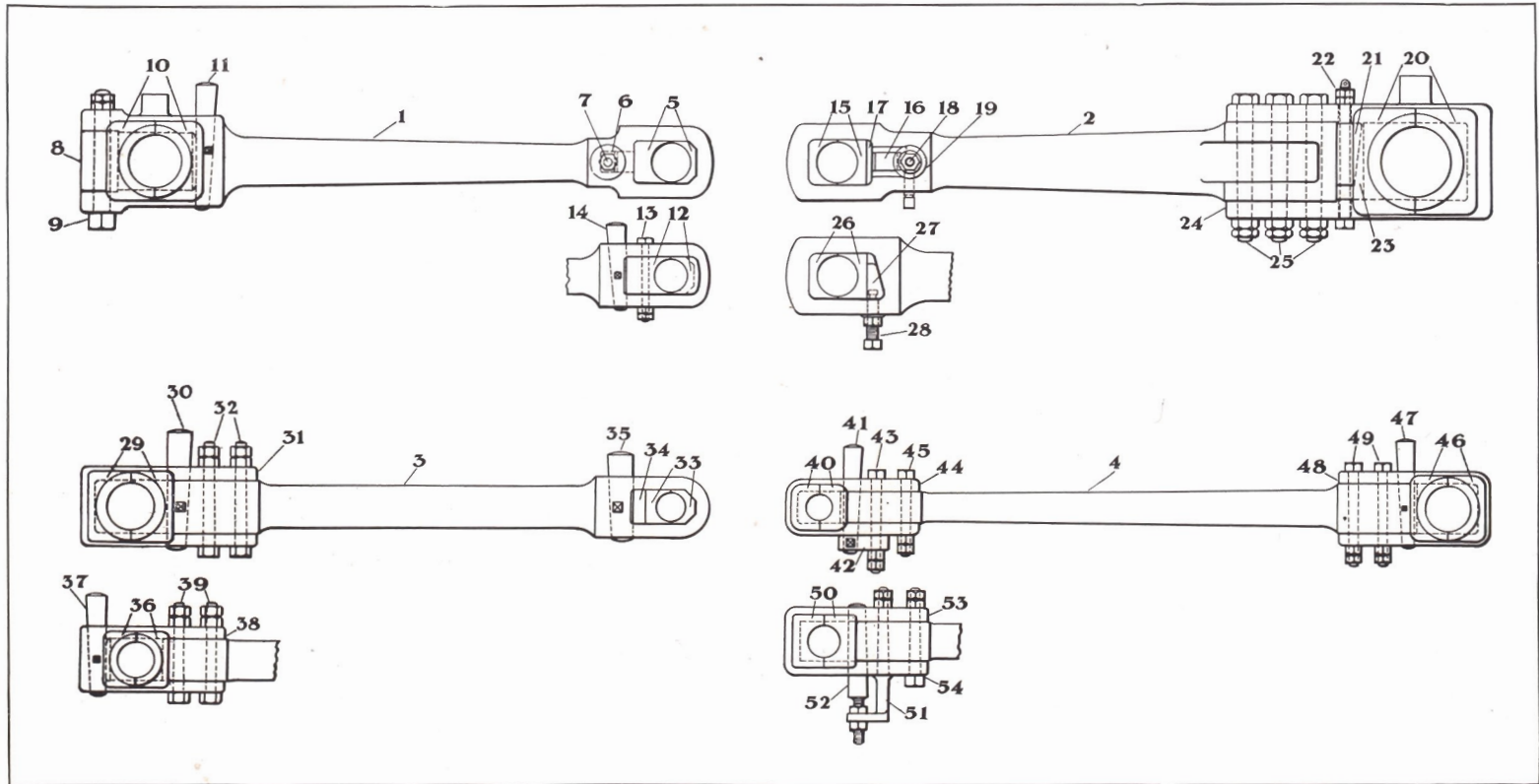



MAIN RODS

PLATE 20

CODE WORD	No.	NAME OF PART	CODE WORD	No.	NAME OF PART
MOSAP		<b>MAIN ROD NO. 1 (Complete) WITH WEDGE FRONT END</b>	MOUXT		<b>MAIN ROD NO. 2 (Complete) WITH VERTICAL FRONT WEDGE</b>
MOSER	1	Main Rod Body (For Wedge Front End)	MOSIS	2	Main Rod Body (For Vertical Front Wedge)
MOSNA	5	" " Brass (Front)	MOUYE	26	" " Brass (Front)
MOSOT	6	" " Wedge	MOVAS	27	" " Wedge (Front)
MOSRE	7	" " Bolt and Washer	MOVET	28	" " Bolt (Front)
MOSSI	8	" " Block (Back)	MOUGN	20	" " Brass (Back)
MOSUV	9	" " Bolt (Back)	MOUHC	21	" " Wedge (Back)
MOTAR	10	" " Brass (Back)	MOULD	22	" " Bolt, Nuts and Cotter (Back)
MOTES	11	" " Key (Back)	MOURF	23	" " Liner (Back)
MOTIT		<b>MAIN ROD NO. 1 (Complete) WITH KEY FRONT END</b>	MOSH	24	" " Strap (Back)
MOSER	1	Main Rod Body (For Key Front End)	MOUWB	25	" " Bolt
MOTLY	12	" " Brass (Front)	MOVIV		<b>MAIN ROD NO. 3 (Complete) WITH KEY IN FRONT OF BRASS</b>
MOTMA	13	" " Bolt	MOSLU	3	Main Rod Body (For Key in Front of Brass)
MOTNE	14	" " Key (Front)	MOVIA	29	" " Brass (Back)
MOSSI	8	" " Block (Back)	MOVME	30	" " Key (Back)
MOSUV	9	" " Bolt (Back)	MOVNI	31	" " Strap
MOTAR	10	" " Brass (Back)	MOVOW	32	" " Bolt
MOTES	11	" " Key (Back)	MOVRO	33	" " Brass (Front)
MOTOV		<b>MAIN ROD NO. 2 (Complete) WITH HORIZONTAL FRONT WEDGE</b>	MOVSU	34	" " Liner (Front)
MOSIS	2	Main Rod Body (For Horizontal Front Wedge)	MOVUX	35	" " Key (Front)
MOTRI	15	" " Brass (Front)	MOWAT		<b>MAIN ROD NO. 3 (Complete) WITH KEY IN BACK OF BRASS</b>
MOTSO	16	" " Wedge (Front)	MOSLU	3	Main Rod Body (For Key in Back of Brass)
MOTUW	17	" " Liner (Front)	MOWEV	36	" " Brass (Back)
MOUBZ	18	" " Key Bolt, Nuts and Cotter (Front)	MOWIW	37	" " Key (Back)
MOUCS	19	" " Washer (Front)	MOWOX	38	" " Strap
MOUGN	20	" " Brass (Back)	MOWTA	39	" " Bolt
MOUHC	21	" " Wedge (Back)	MOVRO	33	" " Brass (Front)
MOULD	22	" " Bolt, Nuts and Cotter (Back)	MOVSU	34	" " Liner (Front)
MOURF	23	" " Liner (Back)	MOVUX	35	" " Key (Front)
MOSH	24	" " Strap (Back)			
MOUWB	25	" " Bolt			

Specify whether for **RIGHT** or **LEFT** side of locomotive.

Specify **BUILDER'S** locomotive **NUMBER** and **CODE WORD** with each order.

NOTE.—Details of forged on grease and oil cups are included when rod is ordered **COMPLETE**. Separate grease and oil cups are not included when rod is ordered **COMPLETE**. For details of **GREASE** and **OIL CUPS** see **PLATE 11**.





PLATE 20-A

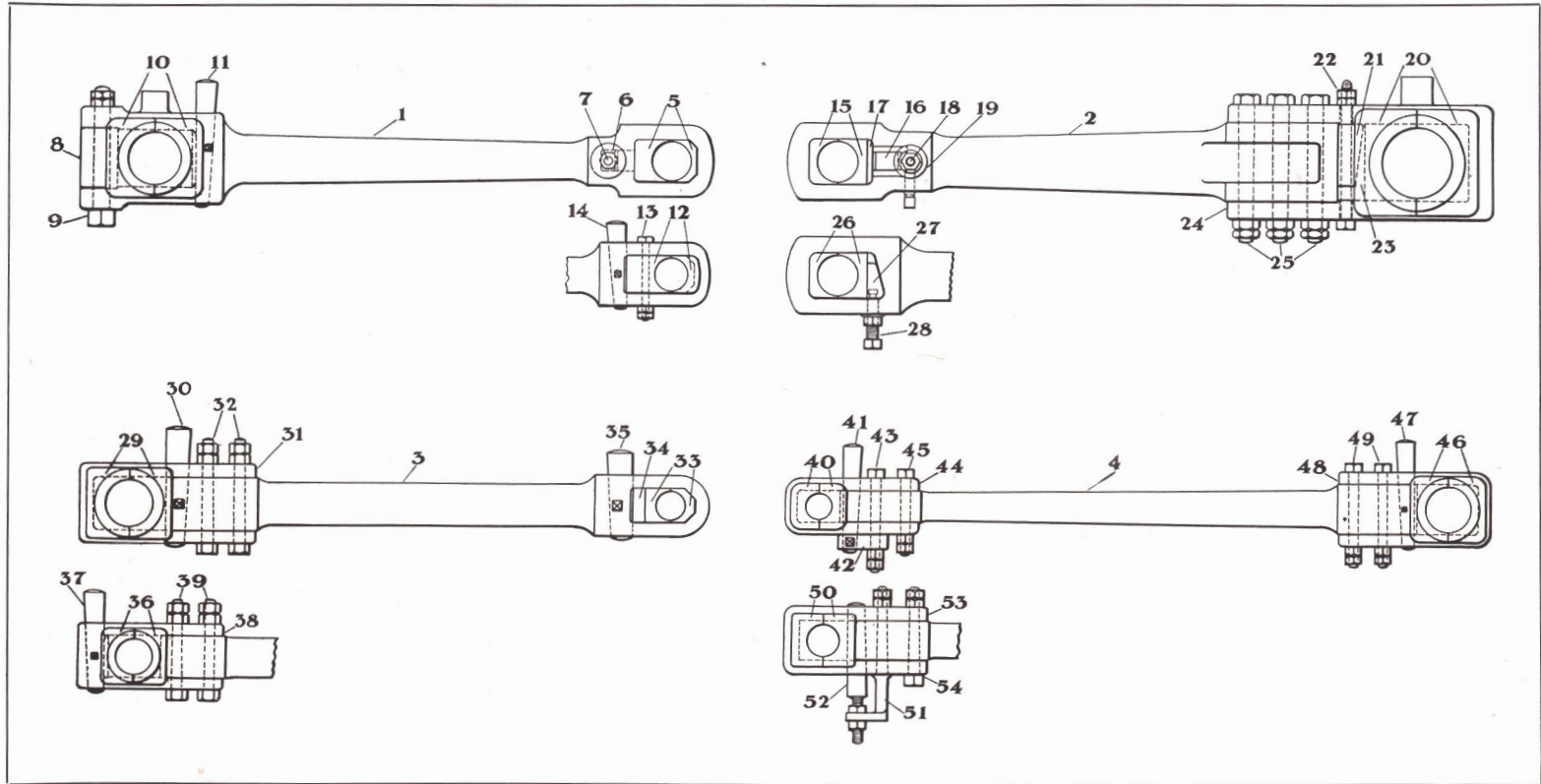



MAIN RODS

PLATE 20-A

CODE WORD	No.	NAME OF PART	CODE WORD	No.	NAME OF PART
MOWWE		<b>MAIN ROD NO. 4 (Complete) WITH KEY HOLDER</b>	MOYOZ		<b>MAIN ROD NO. 4 (Complete) WITH GIB AND KEY</b>
MOSMY	4	Main Rod Body			<b>BOLTS</b>
MOWXI	40	“ “ Brass (Front)	MOSMY	4	Main Rod Body
MOXAV	41	“ “ Key (Front)	MOYTI	50	“ “ Brass (Front)
MOXIX	42	“ “ “ Holder	MOYWO	51	“ “ Gib Bolt
MOXOY	43	“ “ “ Bolt	MOYXU	52	“ “ Key Bolt
MOXTE	44	“ “ Strap (Front)	MOZAX	53	“ “ Strap (Front)
MOXWI	45	“ “ “ Bolt (Front)	MOZEY	54	“ “ “ Bolt (Front)
MOXXO	46	“ “ Brass (Back)	MOXXO	46	“ “ Brass (Back)
MOYAW	47	“ “ Key (Back)	MOYAW	47	“ “ Key (Back)
MOYEX	48	“ “ Strap (Back)	MOYEX	48	“ “ Strap (Back)
MOYIY	49	“ “ “ Bolt (Back)	MOYIY	49	“ “ “ Bolt (Back)

Specify whether for **RIGHT** or **LEFT** side of locomotive.

Specify **BUILDER'S** locomotive **NUMBER** and **CODE WORD** with each order.

**NOTE.**—Details of forged on grease and oil cups are included when rod is ordered **COMPLETE**. Separate grease and oil cups are not included when rod is ordered **COMPLETE**. For details of **GREASE** and **OIL CUPS** see **PLATE 11**.



PLATE 21

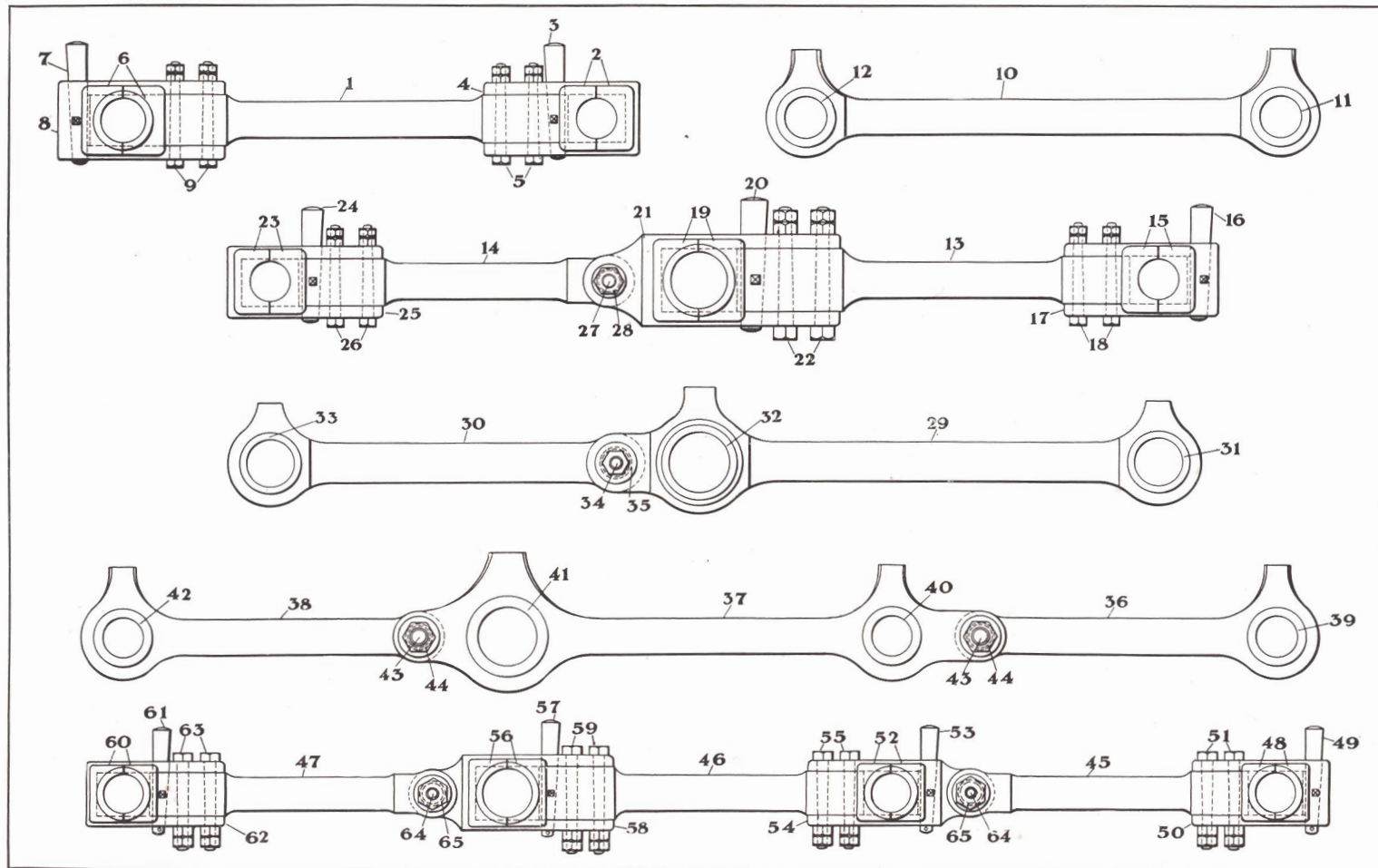



PARALLEL RODS

PLATE 21

CODE WORD	No.	NAME OF PART	CODE WORD	No.	NAME OF PART
MOZIZ		<b>PARALLEL ROD (Complete) STRAP END STYLE, 4-WHEEL LOCOMOTIVE</b>			<b>PARALLEL ROD (Complete) STRAP END STYLE, 6-WHEEL LOCOMOTIVE (Continued)</b>
MUABZ	1	Parallel Rod Body	MUCGI	23	Parallel Rod Brass (Back)
MUACS	2	“ “ Brass (Front)	MUCIH	24	“ “ Key (Back)
MUAGN	3	“ “ Key (Front)	MUCOJ	25	“ “ Strap (Back)
MUAHC	4	“ “ Strap (Front)	MUCUK	26	“ “ “ Bolt (Back)
MUALD	5	“ “ “ Bolt (Front)	MUCVO	27	Knuckle Pin, Washer and Nut
MUARF	6	“ “ Brass (Back)	MUCYM	28	“ “ Thimble
MUASH	7	“ “ Key (Back)	MUDJE		<b>PARALLEL ROD (Complete) SOLID END STYLE, 6-WHEEL LOCOMOTIVE</b>
MUAWB	8	“ “ Strap (Back)			Parallel Rod Body (Front)
MUAXT	9	“ “ “ Bolt (Back)	MUDKI	29	“ “ “ (Back)
MUAYE		<b>PARALLEL ROD (Complete) SOLID END STYLE, 4-WHEEL LOCOMOTIVE</b>	MUDLO	30	“ “ “ Brass (Front)
MUBAD	10	Parallel Rod Body	MUDMU	31	“ “ “ (Middle)
MUBEF	11	“ “ Brass (Front)	MUDNY	32	“ “ “ (Back)
MUBIG	12	“ “ “ (Back)	MUEBS	33	Knuckle Pin, Washer and Nut
MUBOH		<b>PARALLEL ROD (Complete) STRAP END STYLE, 6-WHEEL LOCOMOTIVE</b>	MUECH	34	“ “ Thimble
MUBUJ	13	Parallel Rod Body (Front)	MUEDZ	35	<b>PARALLEL ROD (Complete) SOLID END STYLE, 8-WHEEL LOCOMOTIVE</b>
MUBUK	14	“ “ “ (Back)	MUEFT		Parallel Rod Body (Front)
MUBYL	15	“ “ Brass (Front)	MUEGH	36	“ “ “ (Middle)
MUBZA	16	“ “ Key (Front)	MUEHB	37	“ “ “ (Back)
MUCAF	17	“ “ Strap (Front)	MUELG	38	“ “ “ Brass (Front)
MUCBU	18	“ “ “ Bolt (Front)	MUENK	39	“ “ “ (Intermediate)
MUCCY	19	“ “ “ Brass (Middle)	MUERF	40	“ “ “ (Main)
MUCDA	20	“ “ Key (Middle)	MUESY	41	“ “ “ (Back)
MUCEG	21	“ “ Strap (Middle)	MUEWC	42	Knuckle Pin, Washer and Nut
MUCFE	22	“ “ “ Bolt (Middle)	MUFPA	43	“ “ Thimble
			MUFRE	44	

Specify whether for **RIGHT** or **LEFT** side of locomotive.

Specify **BUILDER'S** locomotive **NUMBER** and **CODE WORD** with each order.

**NOTE.**—Details of forged on grease and oil cups are included when rod is ordered **COMPLETE**. Separate grease and oil cups not included when rod is ordered **COMPLETE**.

For details of **GREASE** and **OIL CUPS** see **PLATE 11**.



PLATE 21-A

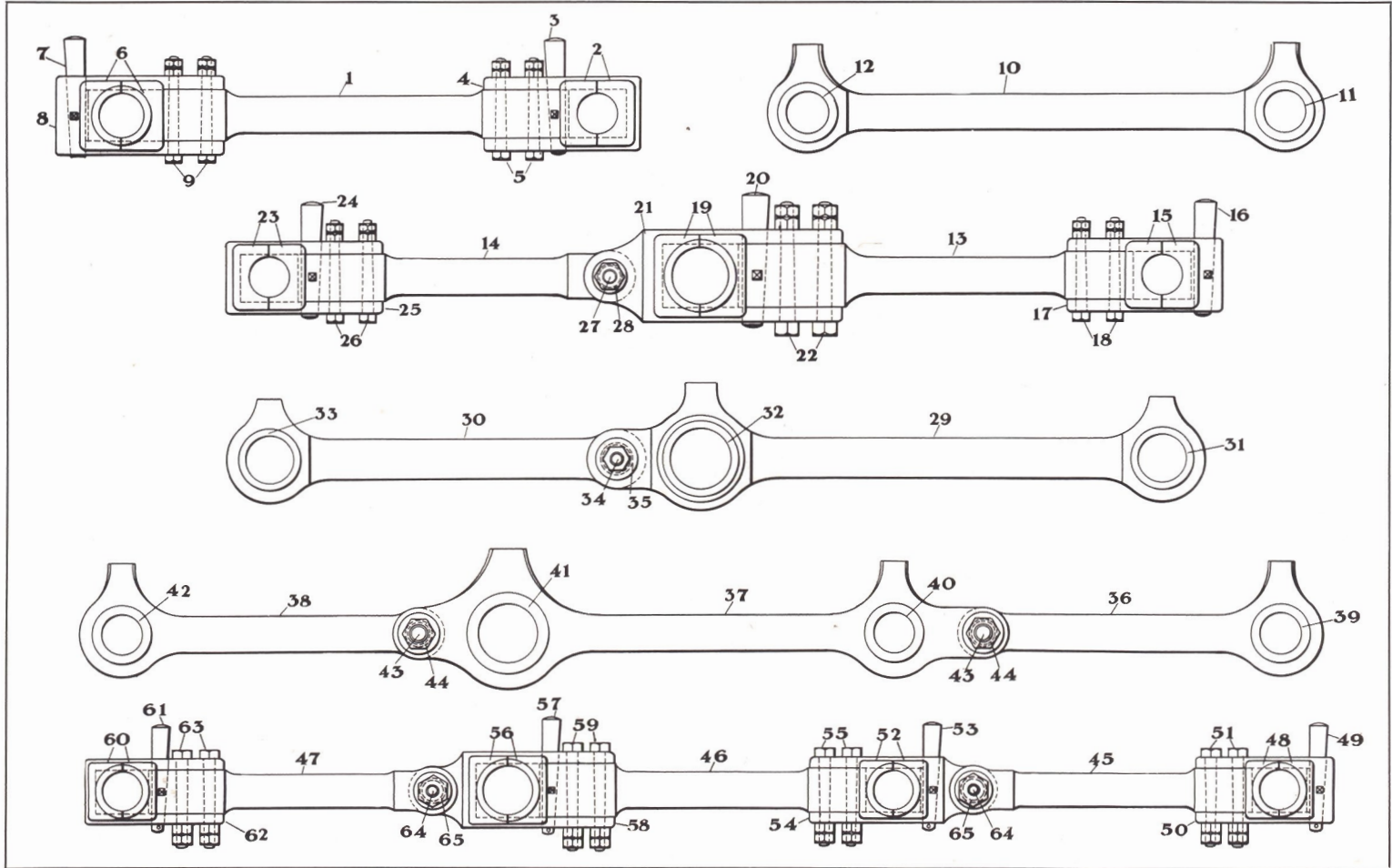



PARALLEL RODS

PLATE 21-A

CODE WORD	No.	NAME OF PART	CODE WORD	No.	NAME OF PART
MUFSI		PARALLEL ROD (Complete) STRAP END STYLE, 8-WHEEL LOCOMOTIVE			PARALLEL ROD (Complete) STRAP END STYLE, 8-WHEEL LOCOMOTIVE (Continued)
MUFTO	45	Parallel Rod Body (Front)	MUHFI	64	Knuckle Pin Washer and Nut
MUFVU	46	“ “ “ (Middle)	MUHGO	65	“ “ Thimble
MUFWY	47	“ “ “ (Back)			
MUGAC	48	“ “ Brass (Front)			
MUGBI	49	“ “ Key (Front)			
MUGCO	50	“ “ Strap (Front)			
MUGDU	51	“ “ “ Bolt (Front)			
MUGED	52	“ “ Brass (Intermediate)			
MUGFY	53	“ “ Key (Intermediate)			
MUGGA	54	“ “ Strap (Intermediate)			
MUGIF	55	“ “ “ Bolt (Intermediate)			
MUGOG	56	“ “ Brass (Main)			
MUGUH	57	“ “ Key (Main)			
MUGVE	58	“ “ Strap (Main)			
MUGYK	59	“ “ “ Bolt (Main)			
MUHBO	60	“ “ Brass (Back)			
MUHCU	61	“ “ Key (Back)			
MUHDY	62	“ “ Strap (Back)			
MUHEH	63	“ “ “ Bolt (Back)			

Specify whether for **RIGHT** or **LEFT** side of locomotive.

Specify **BUILDER'S** locomotive **NUMBER** and **CODE WORD** with each order.

NOTE.—Details of forged on grease and oil cups are included when rod is ordered **COMPLETE**. Separate grease and oil cups not included when rod is ordered **COMPLETE**. For details of **GREASE** and **OIL CUPS** see **PLATE 11**.



PLATE 22

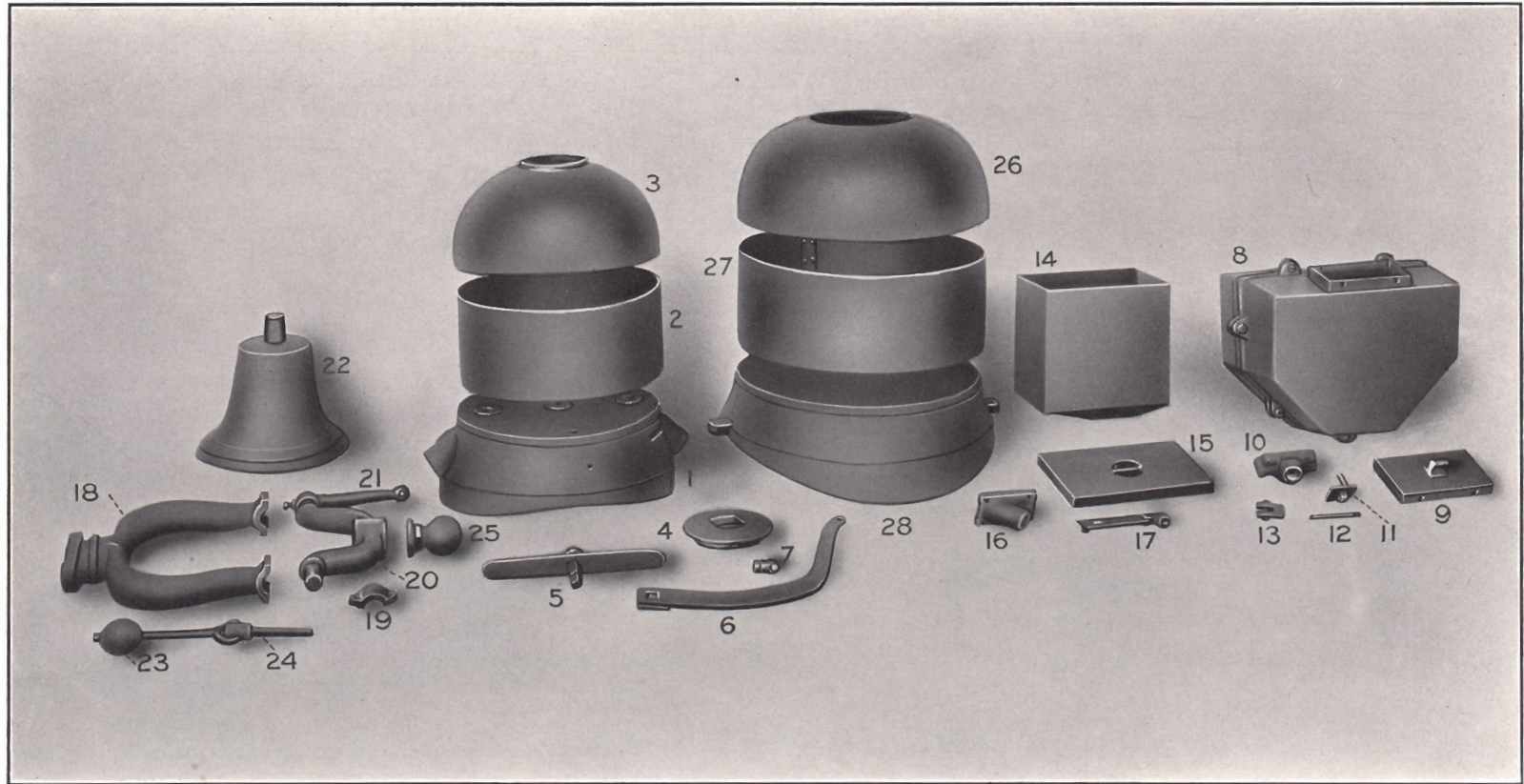



## SANDBOXES, BELL AND DOME CASING

## PLATE 22

CODE WORD	No.	NAME OF PART	CODE WORD	No.	NAME OF PART
MUIHJ	*	<b>SANDBOX</b> (Complete)	MUJEG		<b>BELL</b> (Complete)
MUHOK	1	Sandbox Base	MUJFE	18	Bell Frame
MUHUL	2	“ Body	MUJGI	19	“ “ Cap
MUHVU	3	“ Top	MUJIH	20	“ “ Yoke
MUHYN	4	“ Cover	MUJOJ	21	“ Lever
MUICT	5	“ Valve	MUJUK	22	“ (Brass Part)
MUIDS	*6	“ “ Lever	MUJVO	23	“ Clapper
MUIGZ	7	“ Lever Clevis	MUJYM	24	“ Hanger
MUIHD	*	<b>SIDE SANDBOX</b> (Complete) (Steel Works Style)	MUKAG	25	“ Knob
MUI LJ	8	Sandbox	MUKBY		<b>DOME CASING</b> (Complete)
MUIMP	9	“ Cover	MUKCA	26	Dome Casing Top
MUIPH	10	“ Valve Seat	MUKDE	27	“ “ Body
MUIRK	11	“ Valve	MUKEH	28	“ “ Base
MUIWF	12	“ “ Stem			
MUIYI	13	“ “ “ Clevis			
MUIZY		<b>SIDE SANDBOX</b> (Complete) (Mine Style)			
MUJAF	14	Sandbox			
MUJBU	15	“ Cover			
MUJCY	*16	“ Valve Seat			
MUJDA	17	“ “ and Clevis			

\*Specify whether **FRONT** or **BACK** and **RIGHT** or **LEFT**.

Specify **BUILDER'S** locomotive **NUMBER** and **CODE WORD** with each order.





PLATE 23

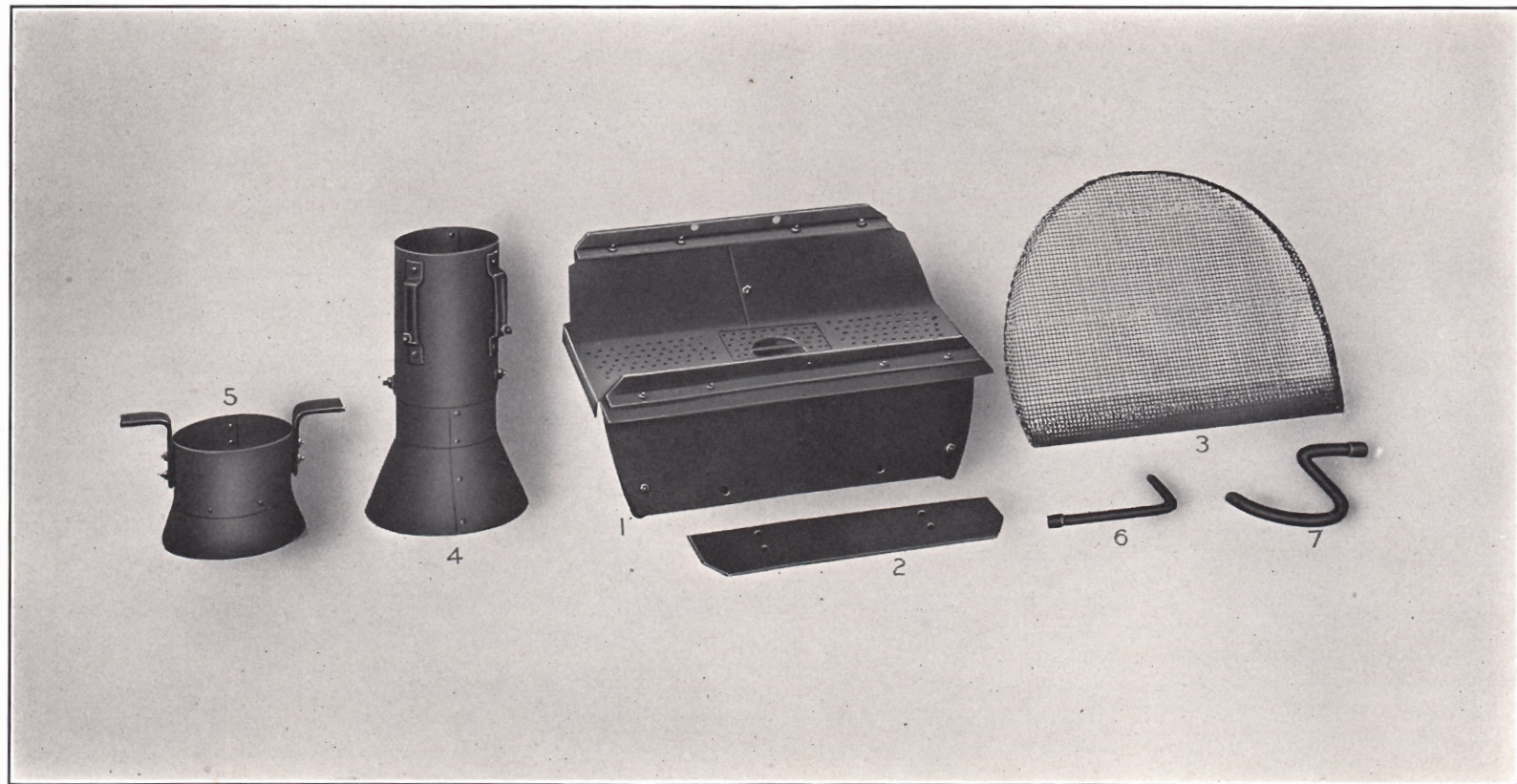



## SMOKEBOX DETAILS

PLATE 23

CODE WORD	No.	NAME OF PART	CODE WORD	No.	NAME OF PART
MUKFI	1	Baffle Plate			
MUKGO	2	Baffle Plate Apron			
MUKIJ	3	Smokebox Netting			
MUKOK	4	Lift Pipe			
MUKUL	5	Lift Pipe			
MUKVU	6	Blower Pipe (Front End)			
MUKYN	7	Blower Pipe (Front End)			

Specify **BUILDER'S** locomotive **NUMBER** and **CODE WORD** with each order.



PLATE 24

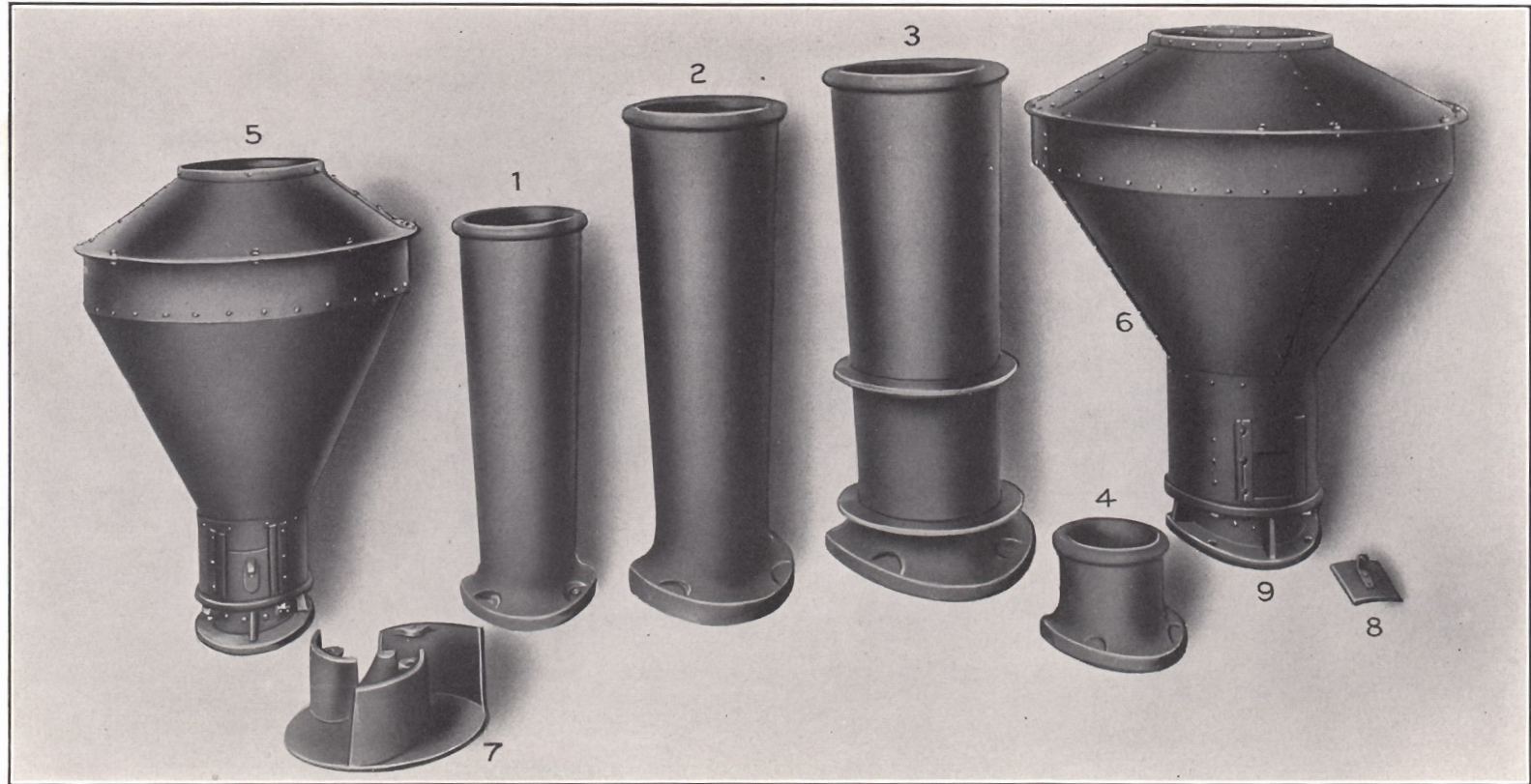



## SMOKE STACKS

## PLATE 24

CODE WORD	No.	NAME OF PART	CODE WORD	No.	NAME OF PART
MULAH	1	Smoke Stack (Cast Iron)			
MULBA	2	Smoke Stack (Cast Iron)			
MULCE	3	Smoke Stack (Cast Iron)			
MULDI	4	Smoke Stack (Cast Iron)			
MULEJ	5	Balloon Stack			
MULFO	6	Balloon Stack			
MULGU	7	Balloon Stack Cone			
MULIK	8	Balloon Stack Cinder Slide			
MULOL	9	Balloon Stack Base			

Specify **BUILDER'S** locomotive **NUMBER** and **CODE WORD** with each order.



PLATE 25

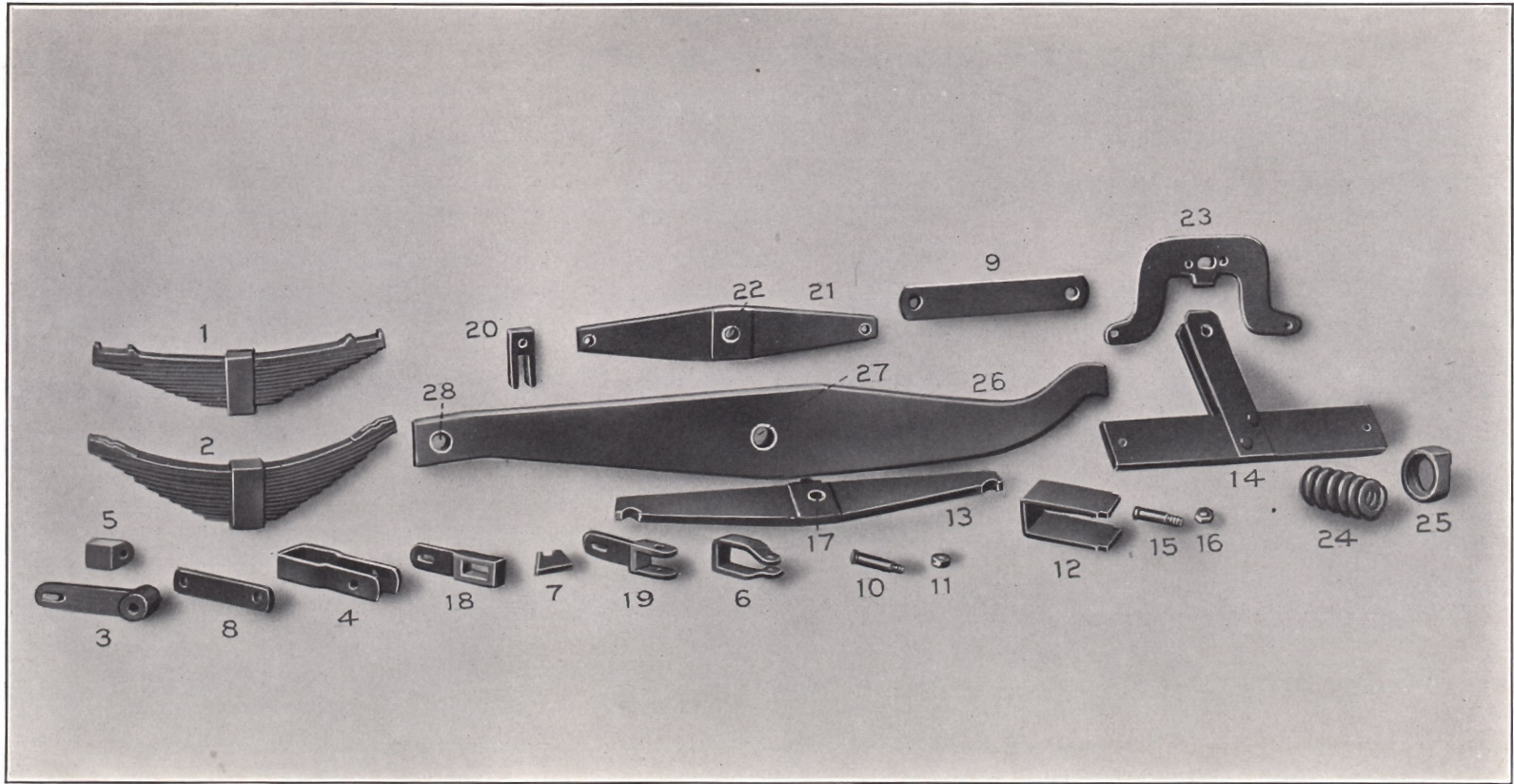



**SPRING RIGGING FOR DRIVING WHEELS**

**PLATE 25**

CODE WORD	No.	NAME OF PART	CODE WORD	No.	NAME OF PART
MULUM	†1	<b>Spring</b> (Lugged)	MUPOP	23	<b>Driving Box Equalizer</b>
MULVY	†2	<b>Spring</b> (Standard) (With Slots for Hangers)	MUPPU	24	<b>Helical Spring</b>
MULYO	†3	<b>Spring Hanger</b>	MUPRY	*25	<b>Helical Spring Seat</b>
MUMAJ	†4	<b>Spring Hanger</b>	MUPUR	26	<b>Engine Truck Equalizer</b>
MUMBE	5	<b>Spring Hanger Block</b>	MUPXE	27	<b>Engine Truck Equalizer Fulcrum Bushing</b>
MUMCI	6	<b>Spring Hanger Clamp</b>	MUPZF	28	<b>Engine Truck Equalizer Rear Bushing</b>
MUMDO	7	<b>Spring Hanger Gib</b>			
MUMEK	†8	<b>Spring Hanger Link</b>			
MUMFU	†9	<b>Spring Hanger Link</b>			
MUMKA	*10	<b>Spring Hanger Pin</b>			
MUMLE	11	<b>Spring Hanger Pin Nut</b>			
MUNAK	†12	<b>Spring Saddle</b>			
MUNEL	13	<b>Cross Equalizer</b>			
MUNIM	14	<b>Cross Equalizer Cross Brace</b>			
MUNON	15	<b>Cross Equalizer Pin</b>			
MUNUP	16	<b>Cross Equalizer Pin Nut</b>			
MUNYR	17	<b>Cross Equalizer Bushing</b>			
MUPAL	18	<b>Cross Equalizer Spring Hanger</b>			
MUPEM	19	<b>Cross Equalizer Spring Hanger</b>			
MUPIN	20	<b>Cross Equalizer Spring Hanger Link</b>			
MUPMI	21	<b>Side Equalizer</b>			
MUPNO	22	<b>Side Equalizer Bushing</b>			

†Specify whether **FRONT**, **INTERMEDIATE**, **MAIN** or **BACK**.

\*Specify whether **UPPER** or **LOWER**.

Specify **BUILDER'S** locomotive **NUMBER** and **CODE WORD** with each order.



PLATE 26

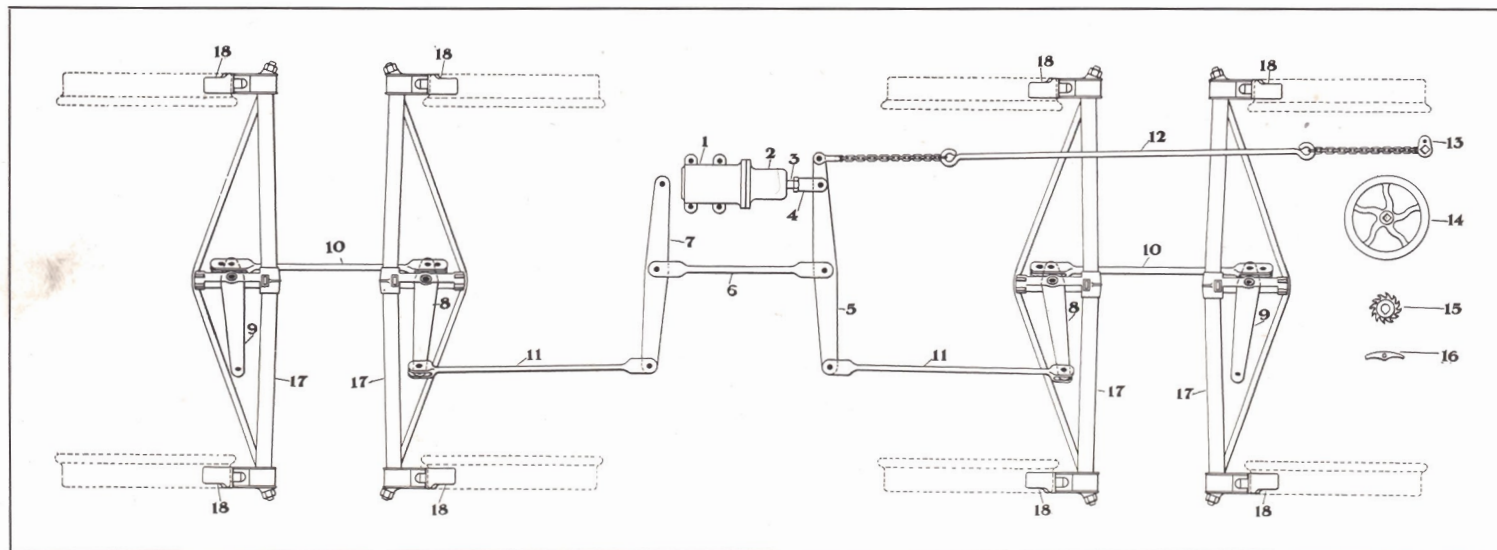



**TENDER BRAKE**

**PLATE 26**

<b>CODE WORD</b>	<b>No.</b>	<b>NAME OF PART</b>	<b>CODE WORD</b>	<b>No.</b>	<b>NAME OF PART</b>
MURAM	1	Tender Brake Cylinder			
MUREN	2	Tender Brake Cylinder Spring Pocket			
MURIP	3	Tender Brake Cylinder Piston and Rod			
MURLI	4	Tender Brake Piston Rod Crosshead			
MURMO	5	Tender Brake Cylinder Lever (Front)			
MURNU	6	Tender Brake Cylinder Lever Connecting Rod			
MUROR	7	Tender Brake Cylinder Lever (Back)			
MURPY	8	Tender Brake Live Lever			
MURSA	9	Tender Brake Dead Lever			
MURUS	10	Tender Brake Live and Dead Lever Connecting Rod			
MUSAN	11	Tender Brake Cylinder and Live Lever Connecting Rod			
MUSEP	12	Tender Hand Brake Connecting Rod			
MUSIR	13	Tender Hand Brake Staff Reel			
MUSLO	14	Tender Brake Hand Wheel			
MUSMU	15	Tender Hand Brake Ratchet			
MUSNY	16	Tender Brake Ratchet Catch			
MUSOS	17	Tender Brake Beam			
MUSRA	18	Tender Brake Shoe			

Specify **BUILDER'S** locomotive **NUMBER** and **CODE WORD** with each order.





PLATE 27

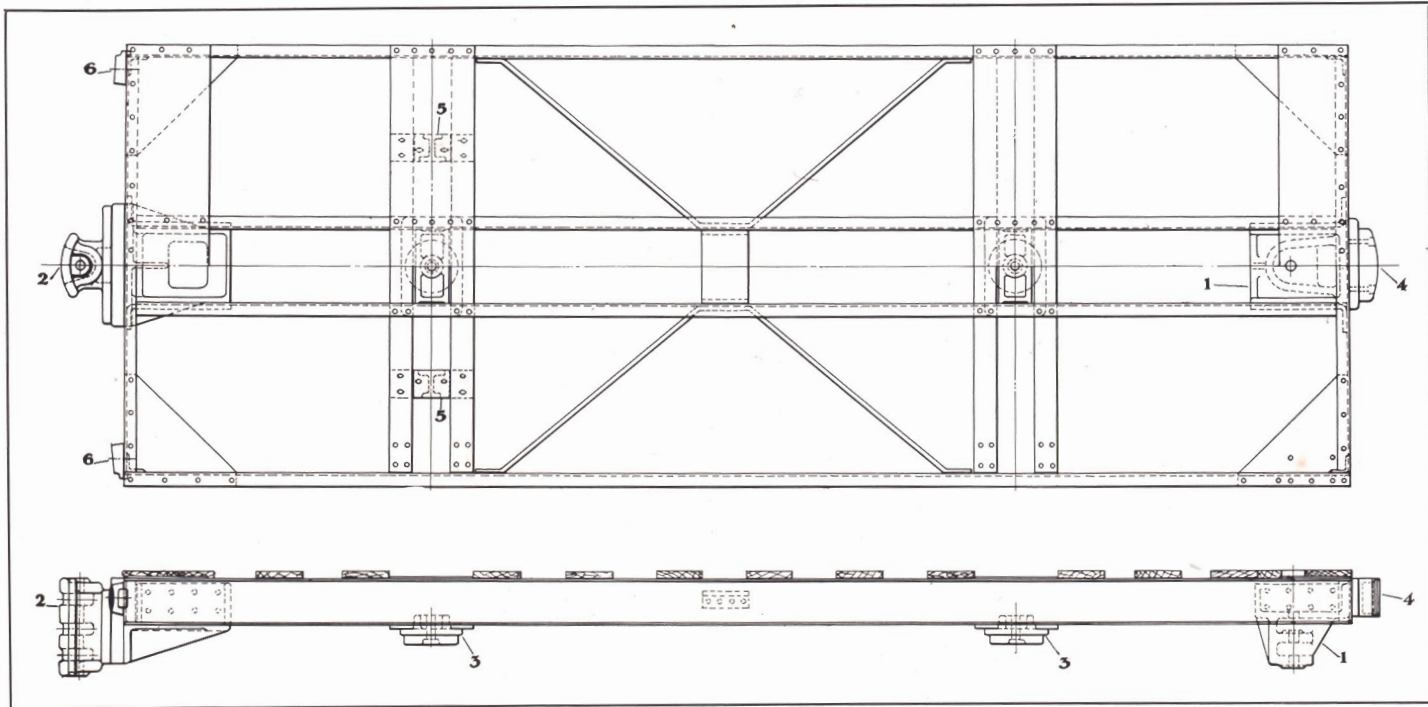



STEEL TENDER FRAME

PLATE 27

CODE WORD	No.	NAME OF PART	CODE WORD	No.	NAME OF PART
MUSSE		<b>TENDER FRAME</b> (Complete)			
MUSUT	1	Tender Frame Drawhead (Front)			
MUTAP	2	“ “ “ (Back)			
MUTER	3	“ “ Center Plate (Male)			
MUTIS	4	“ “ Chafing Plate			
MUTLU	5	“ “ Side Bearing			
MUTMY	6	“ “ Pushpole Pocket			

Specify **BUILDER'S** locomotive **NUMBER** and **CODE WORD** with each order.



PLATE 28

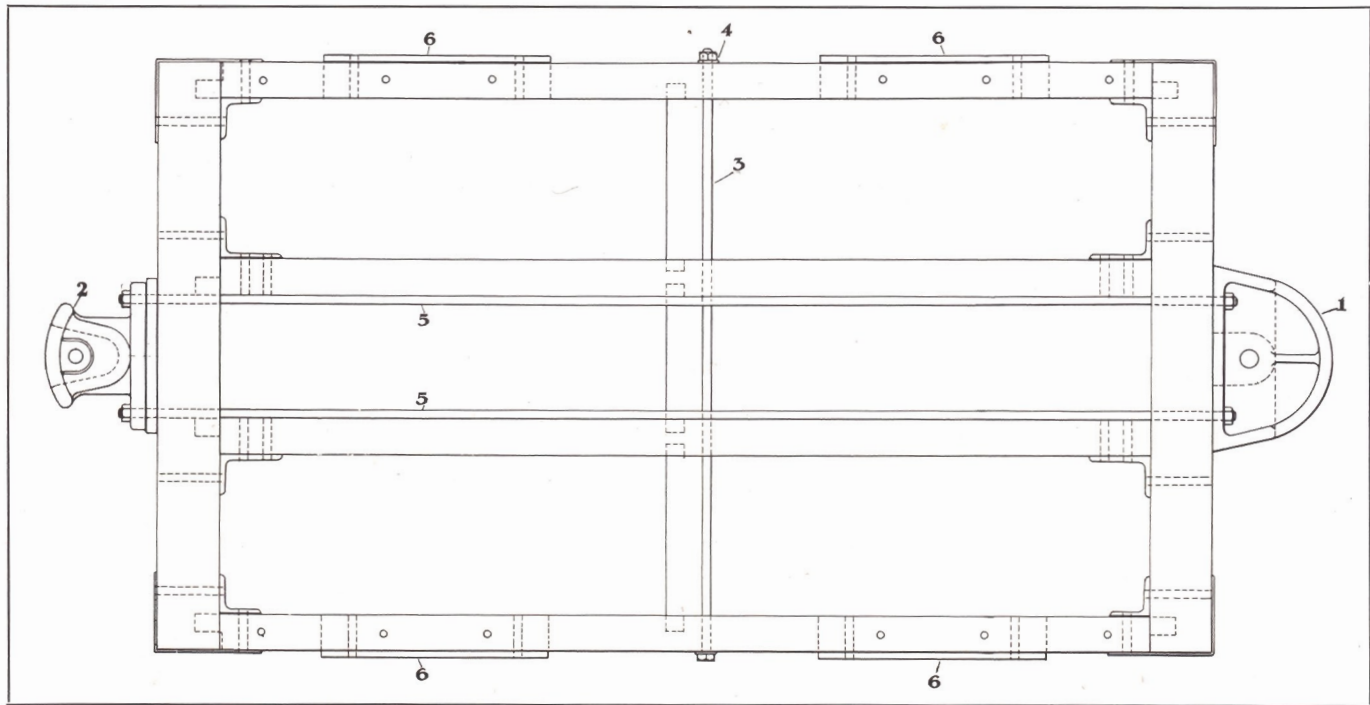



**WOODEN TENDER FRAME**

**PLATE 28**

CODE WORD	No.	NAME OF PART	CODE WORD	No.	NAME OF PART
MUTNA		<b>TENDER FRAME</b> (Complete)			
MUTOT	1	Tender Frame Drawhead (Front)			
MUTRE	2	“ “ “ (Back)			
MUTSI	3	“ “ Tie Rod (Transverse)			
MUTUV	4	“ “ “ “ Washer			
MUUBE	5	“ “ Draw Rod			
MUUCI	6	“ Pedestal			

Specify **BUILDER'S** locomotive **NUMBER** and **CODE WORD** with each order.



PLATE 29

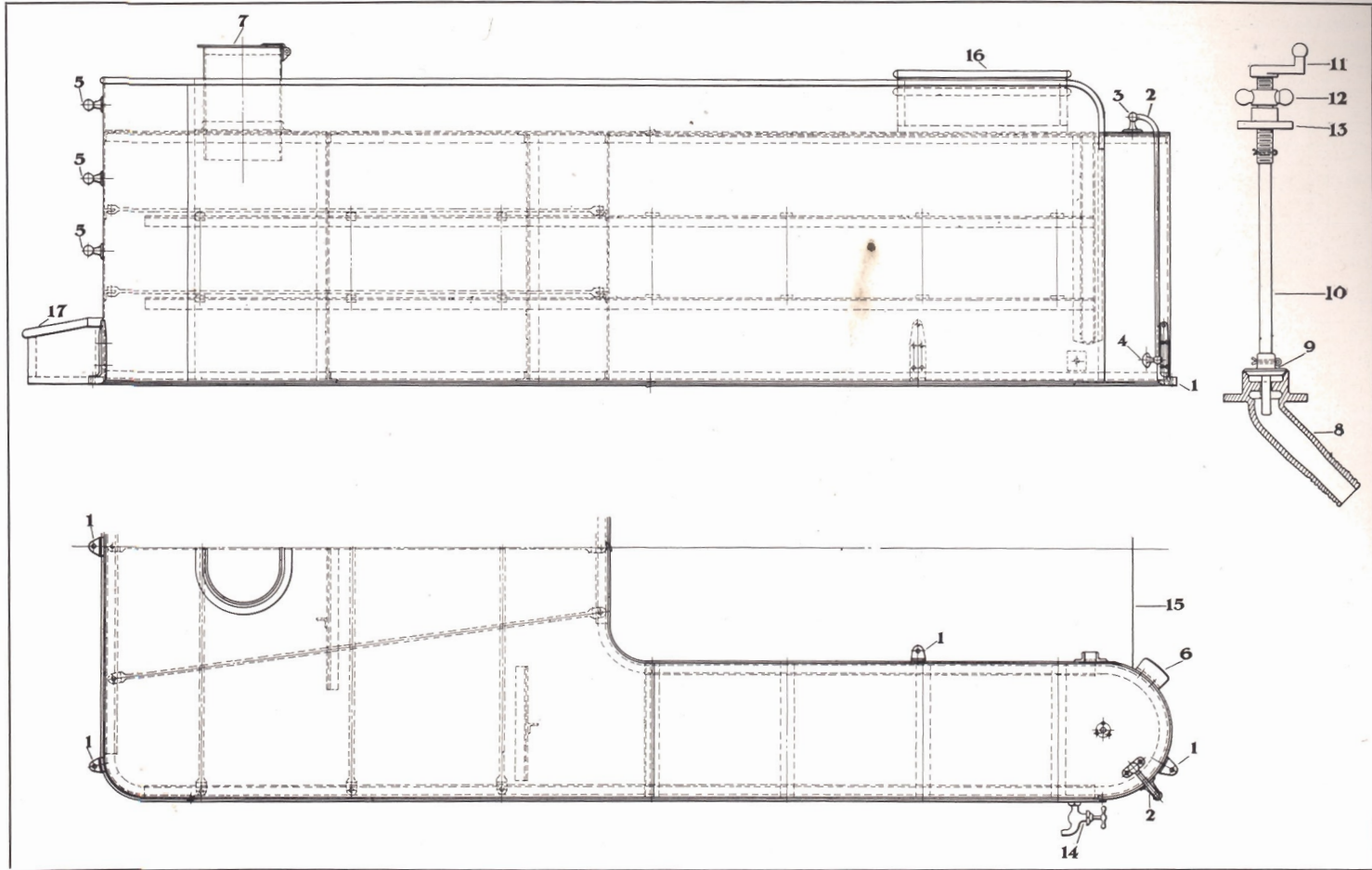



**TENDER TANK**

**PLATE 29**

CODE WORD	No.	NAME OF PART	CODE WORD	No.	NAME OF PART
MUUDO		<b>TENDER TANK</b> (Complete)			
MUUFU	1	Tender Tank Lug			
MUUGY	2	“ “ Handrail			
MUUHZ	3	“ “ “ Column (Upper)			
MUUKS	4	“ “ “ “ (Lower)			
MUULC	5	“ “ Rear Handrail Column			
MUUNT	6	“ Brake Staff Bracket			
MUURD	7	“ Tank Manhole Cover			
MUUSP	8	“ “ Gooseneck			
MUUTH	9	“ “ Valve			
MUUWG	10	“ “ “ Rod			
MUUYA	11	“ “ “ “ Handle			
MUVAR	12	“ “ “ “ Nut			
MUVES	13	“ “ “ “ Flange			
MUVIT	14	“ “ Water Spigot			
MUVLY	15	“ “ Shoveling Plate			
MUVMA	16	“ “ Tool Box (Upper)			
MUVNE	17	“ “ “ “ (Back)			

Specify **BUILDER'S** locomotive **NUMBER** and **CODE WORD** with each order.



PLATE 30

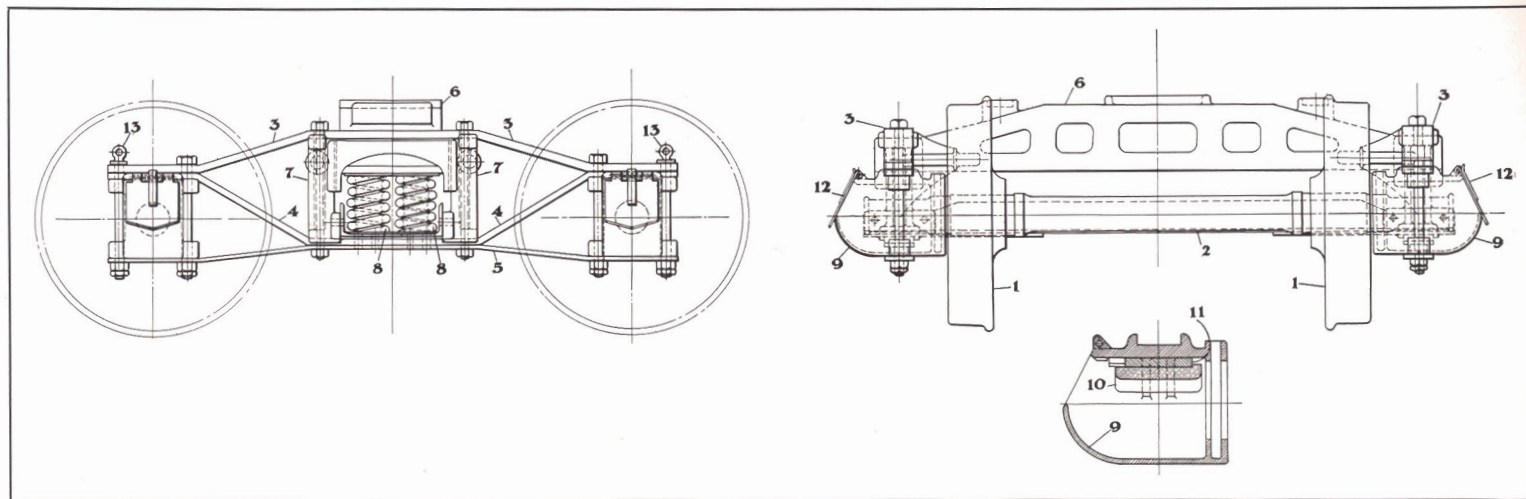



**TENDER TRUCK**

**PLATE 30**

CODE WORD	No.	NAME OF PART	CODE WORD	No.	NAME OF PART
MUVOV		<b>TENDER TRUCK</b> (Complete)			
MUVRI	1	Tender Truck Wheel			
MUVSO	2	“ “ Axle			
MUVUW	3	“ “ Arch Bar (Top)			
MUWAS	4	“ “ “ “ (Bottom)			
MUWET	5	“ “ Tie Bar			
MUWIV	6	“ “ Bolster			
MUWLA	*7	“ “ Frame Column			
MUWME	8	“ “ Springs			
MUWNI	9	“ “ Box			
MUWOW	10	“ “ “ Brass			
MUWRO	11	“ “ “ Wedge			
MUWSU	12	“ “ “ Lid			
MUWUX	13	“ “ Safety Chain Eye Bolt			
MUWUT		<b>Two Tender Wheels on Axle</b>			

\*Specify whether **RIGHT** or **LEFT**.

Specify **BUILDER'S** locomotive **NUMBER** and **CODE WORD** with each order.





PLATE 31

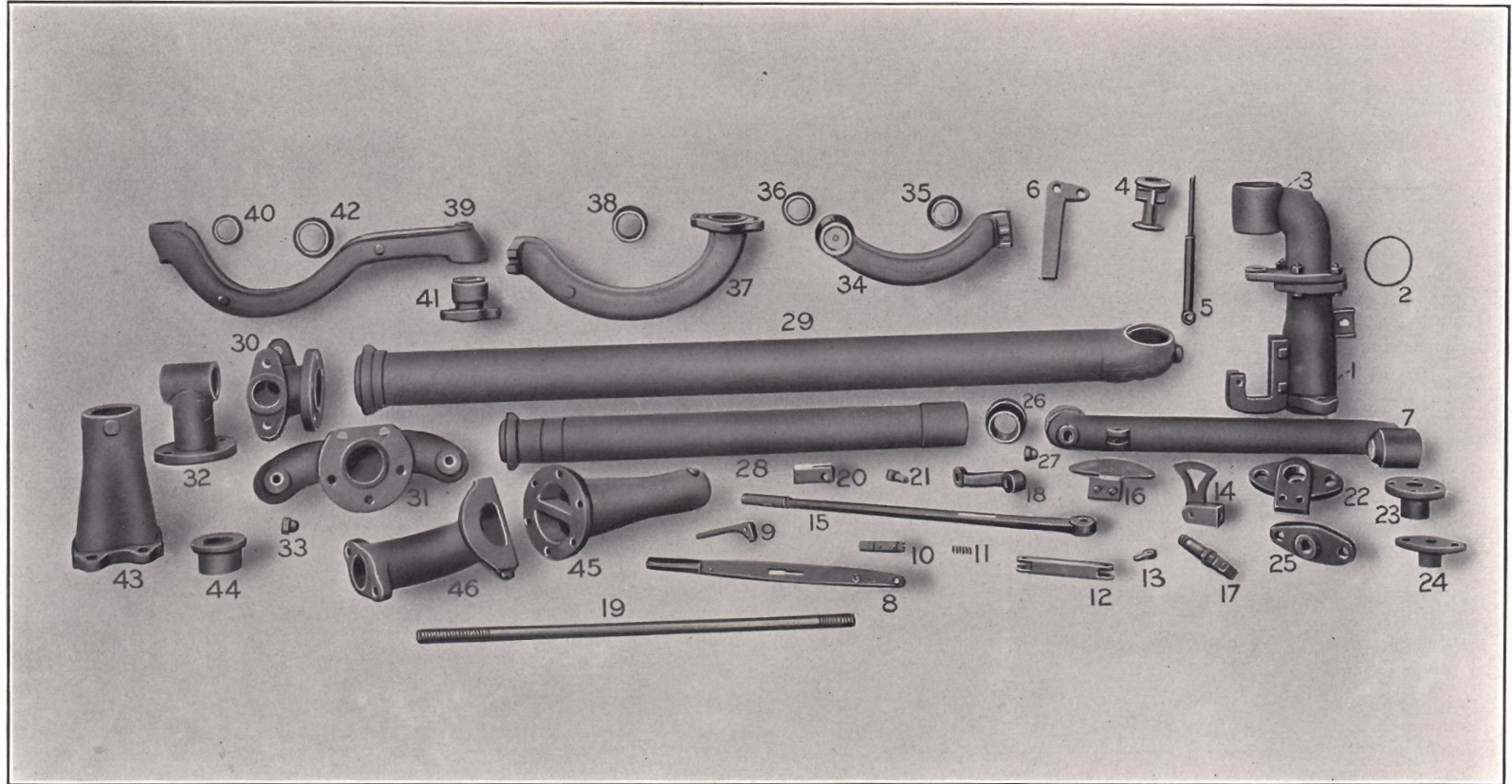



Throttle, Steam and Dry Pipes and Fittings

PLATE 31

CODE WORD	No.	NAME OF PART	CODE WORD	No.	NAME OF PART
MUXAT		<b>THROTTLE</b> (Complete)	MUZZY	19	<b>Throttle Stem</b> (Outside Stem Which Passes Thru Throttle Gland)
MUXEV	1	Throttle Stand Pipe	MYAAC	20	<b>Throttle Stem Clevis</b>
MUXIW	2	" Copper Joint	MYABI	21	<b>Throttle Stem Clevis Pin</b>
MUXOX	3	" Elbow	MYACO	22	<b>Throttle Stuffing Box</b>
MUXTA	4	" Valve	MYADU	23	<b>Throttle Stuffing Box</b>
MUXWE	5	" " Stem (Inside Stem Which Passes Thru Valve)	MYAED	24	<b>Throttle Gland</b>
MUXXI	6	" Bell Crank	MYAFY	25	<b>Throttle Gland</b>
MUYAV		<b>THROTTLE</b> (Complete)	MYAGA	26	<b>Throttle-Dry Pipe Ball Joint</b>
MUYEW	7	Throttle Elbow	MYAIF	27	<b>Throttle-Dry Pipe Ball Nut</b>
MUXXI	6	" Bell Crank	MYAOG	28	<b>Dry Pipe</b>
MUXWE	5	" Valve Stem (Inside Stem Which Passes Thru Valve)	MYAUH	29	<b>Dry Pipe</b>
MUXTA	4	" Valve	MYAVE	30	<b>Tee Head</b>
MUYIX		<b>THROTTLE LEVER</b> (Complete)	MYAYK	31	<b>Tee Head</b>
MUYOY	8	Throttle Lever Body	MYBBE	32	<b>Tee Head</b>
MUYTE	9	" " Handle	MYBCI	33	<b>Tee Head Ball Nut</b>
MUYWI	10	" " Latch	MYBDO	*34	<b>Steam Pipe</b> (Upright)
MUYXO	11	" " " Spring	MYBFU	35	<b>Steam Pipe-Cylinder Ball Joint</b>
MUZAW	12	" " Link	MYBGY	36	<b>Steam Pipe-Tee Head Ball Joint</b>
MUZEX	13	" " Eye Bolt	MYBHA	*37	<b>Steam Pipe</b> (Upright)
MUZIY	14	" " Quadrant	MYBIB	38	<b>Steam Pipe-Cylinder Ball Joint</b>
MUZOZ		<b>THROTTLE LEVER</b> (Complete)	MYBJK	*39	<b>Steam Pipe</b> (Upright)
MUZTI	15	Throttle Lever Body	MYBLM	40	<b>Steam Pipe-Tee Head Ball Joint</b>
MUYTE	9	" " Handle	MYBON	*41	<b>Horizontal Steam Pipe</b>
MUYWI	10	" " Latch	MYBRP	42	<b>Horizontal Steam Pipe Ball Joint</b>
MUYXO	11	" " " Spring	MYBUS	43	<b>Exhaust Pipe</b> (Upright)
MUZWO	16	" " Quadrant	MYBYT	44	<b>Exhaust Nozzle</b>
MUZ XO	17	<b>Throttle Lever Shaft</b>	MYBAV	45	<b>Exhaust Pipe</b> (Upright)
MUZYP	18	<b>Throttle Lever Crank</b>	MYBEW	*46	<b>Horizontal Exhaust Pipe</b>

\*Specify whether **RIGHT** or **LEFT** side of locomotive.

Specify **BUILDER'S** locomotive **NUMBER** and **CODE WORD** with each order.



PLATE 32

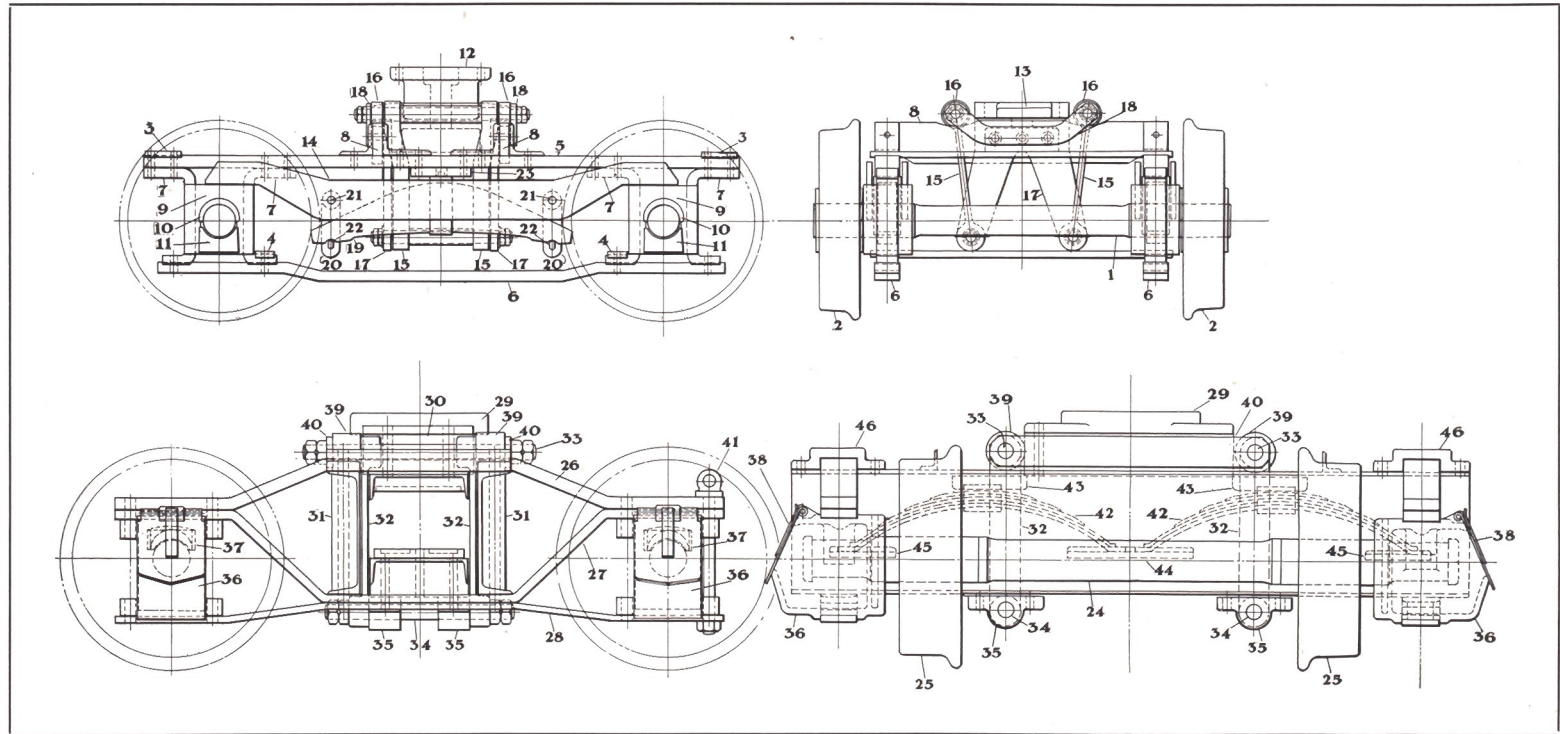



**FOUR WHEEL ENGINE TRUCKS**

**PLATE 32**

CODE WORD	No.	NAME OF PART	CODE WORD	No.	NAME OF PART
MYCAD		<b>ENGINE TRUCK</b> (Front) (Complete)	MYEBY		<b>ENGINE TRUCK</b> (Back) (Complete)
MYCBO	1	Engine Truck Axle	MYECA	24	Engine Truck Axle
MYCCU	2	“ “ Wheel	MYEDE	25	“ “ Wheel
MYCDY	3	“ “ Crossbrace (Upper)	MYEEH	26	“ “ Arch Bar (Upper)
MYCEF	4	“ “ “ (Lower)	MYEFI	27	“ “ “ “ (Lower)
MYCFA	5	“ “ Pedestal Brace (Upper)	MYEGO	28	“ “ “ “ Tie Bar
MYCGE	6	“ “ “ “ (Lower)	MYEIJ	29	“ “ Center Plate (Male)
MYCIG	7	“ “ Pedestal	MYEOK	30	“ “ “ “ (Female)
MYCOH	8	“ “ Frame	MYEUL	31	“ “ Column
MYCUJ	9	“ “ Box	MYEVU	32	“ “ Hanger
MYCVI	10	“ “ “ Brass	MYEYN	33	“ “ “ Pin (Upper)
MYCYL	11	“ “ “ Cellar	MYFAB	34	“ “ “ “ (Lower)
MYDAF	12	“ “ Center Plate (Male)	MYFEC	35	“ “ “ “ Bearing
MYDBU	13	“ “ “ “ (Female)	MYFID	36	“ “ Oil Box
MYDCY	14	“ “ Side Equalizer	MYFOF	37	“ “ “ “ Brass
MYDEG	15	“ “ Hanger	MYFUG	38	“ “ “ “ Cover
MYDFE	16	“ “ Rollers	MYFYJ	39	“ “ Rollers
MYDGI	17	“ “ Spreader (Lower)	MYFFA	40	“ “ Spreader
MYDIH	18	“ “ “ (Upper)	MYFVO	41	“ “ Safety Chain Eye Bolt
MYDOJ	19	“ “ Spring	MYFME	42	“ “ Spring
MYDUK	20	“ “ “ Hanger	MYFNI	43	“ “ “ Seat (Upper)
MYDVO	21	“ “ “ “ Pin	MYFPU	44	“ “ “ “ (Lower Middle)
MYDYM	22	“ “ “ “ Gib	MYFSK	45	“ “ “ “ (Lower End)
MYEAG	23	“ “ “ Seat	MYFTY	46	“ “ Tie Plate
			MYFWL		<b>Two Engine Truck Wheels on Axle.</b>

Specify **BUILDER'S** locomotive **NUMBER** and **CODE WORD** with each order.



PLATE 33

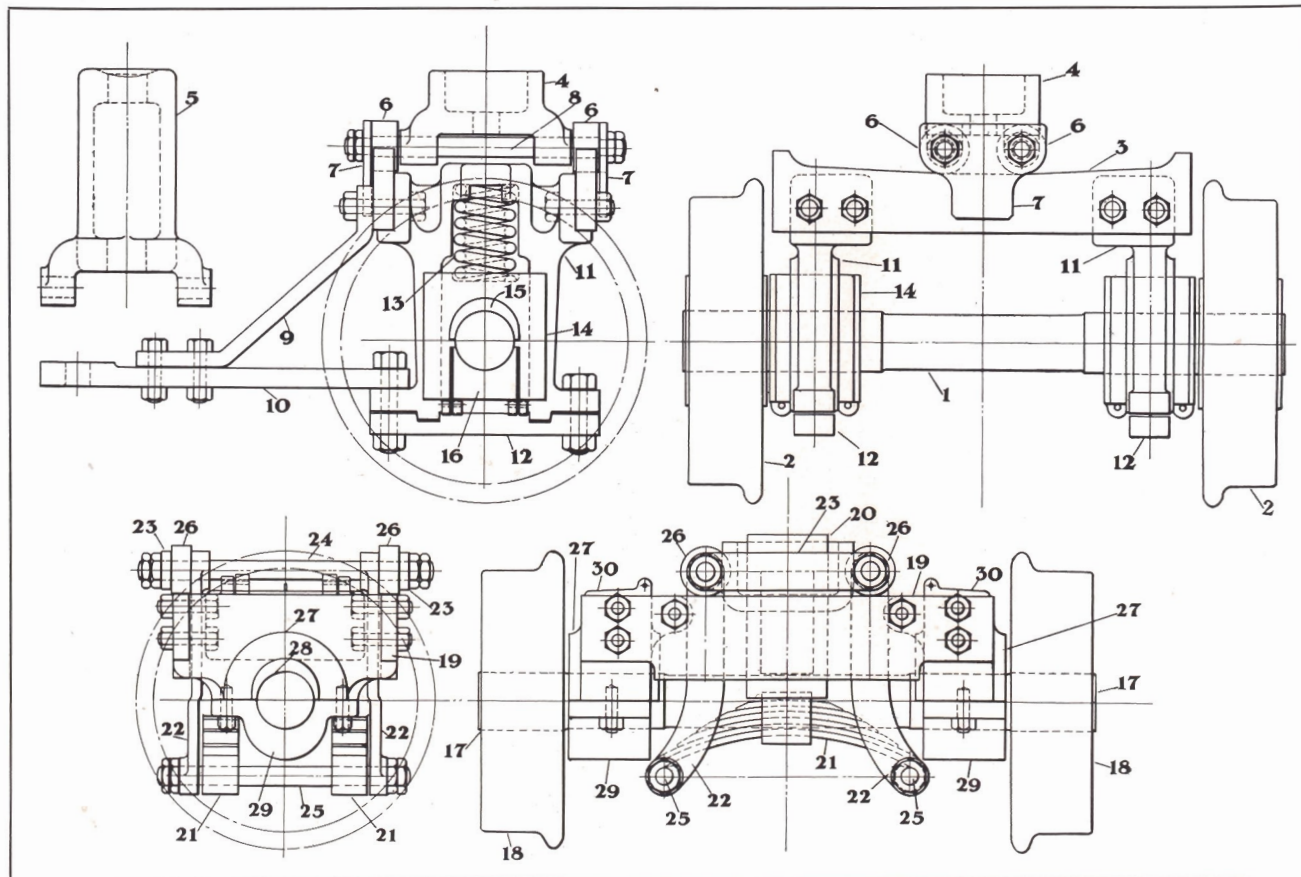



**TWO WHEEL ENGINE TRUCKS**

**PLATE 33**

CODE WORD	No.	NAME OF PART	CODE WORD	No.	NAME OF PART
MYGAH		<b>ENGINE TRUCK (Complete) WITH COIL SPRINGS</b>	MYHFU		<b>ENGINE TRUCK (Complete) WITH PLATE SPRINGS</b>
MYGBA	1	Engine Truck Axle	MYHKA	17	Engine Truck Axle
MYGCE	2	“ “ Wheel	MYHLY	18	“ “ Wheel
MYGDI	3	“ “ Frame	MYHMN	19	“ “ Frame
MYGEJ	*4	“ “ Center Casting (Female)	MYHIP	20	“ “ Center Casting (Female)
MYGFO	*5	“ “ “ “ (Male)	MYHOR	21	“ “ Spring
MYGGU	6	“ “ Roller	MYHYS	22	“ “ “ Hanger
MYGIK	7	“ “ “ Guide	MYIBS	23	“ “ Hanger Spreader
MYGOL	8	“ “ “ Pin	MYICH	24	“ “ “ Pin (Upper)
MYGUM	9	“ “ Dragbrace	MYIDZ	25	“ “ “ “ (Lower)
MYGVY	10	“ “ “ Support	MYIFT	26	“ “ Roller
MYGYO	11	“ “ Pedestal	MYIGH	27	“ “ Oil Box
MYHAJ	12	“ “ “ Brace	MYIHB	28	“ “ “ “ Brass
MYHBE	13	“ “ Spring	MYILG	29	“ “ “ “ Cellar
MYHCI	14	“ “ Box	MYINK	30	“ “ “ “ Lid
MYHDO	15	“ “ “ Brass	MYGUM	9	“ “ Dragbrace
MYHEK	16	“ “ “ Cellar	MYIRJ		<b>Two Engine Truck Wheels on Axle</b>

\*Not used on the same locomotive.

Specify **BUILDER'S** locomotive **NUMBER** and **CODE WORD** with each order.



PLATE 34

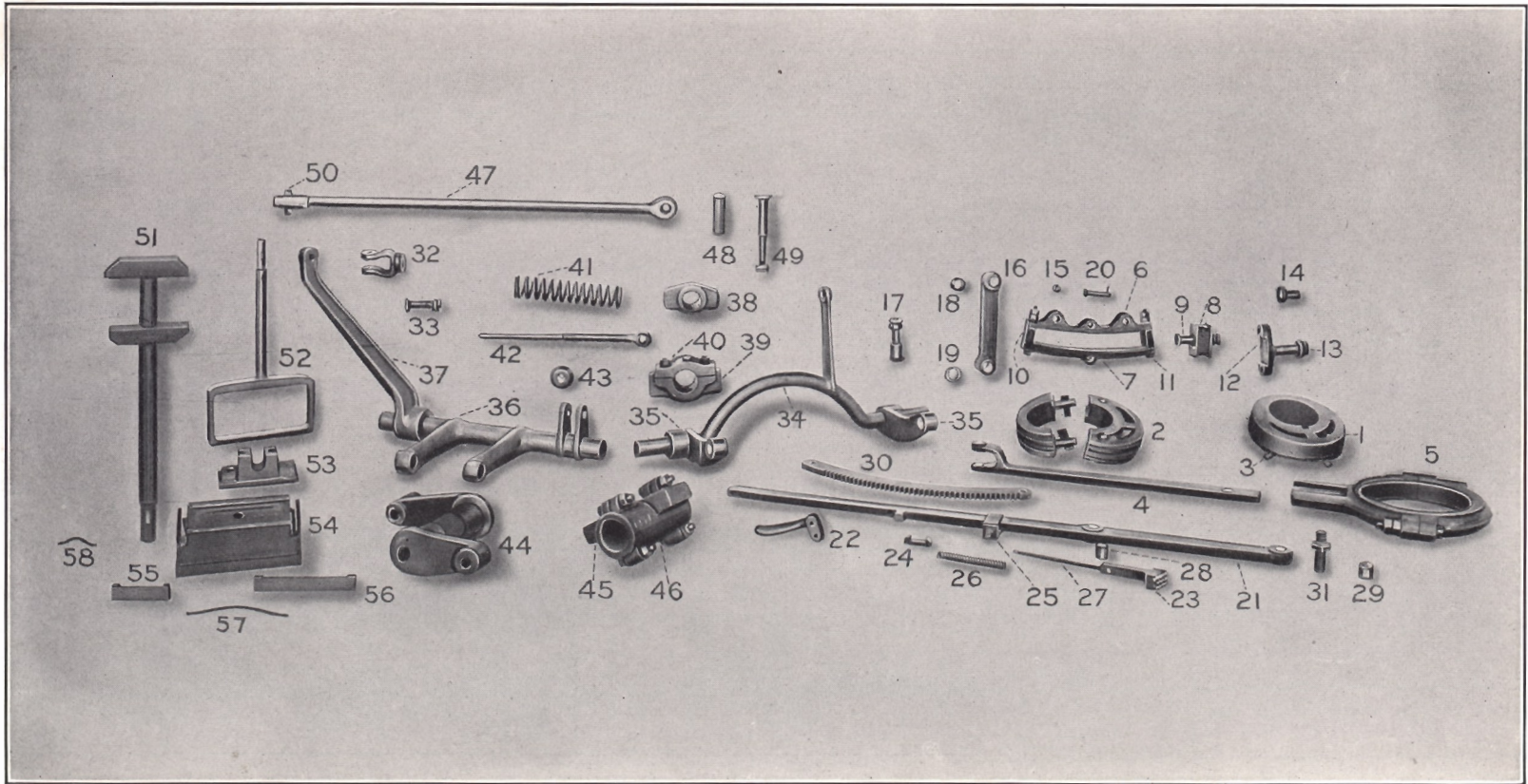



VALVE MOTION DETAILS

PLATE 34

CODE WORD	No.	NAME OF PART	CODE WORD	No.	NAME OF PART
MYISY	1	Eccentric (Solid)	MYLPY	30	Reverse Lever Quadrant. Note: FURNISH TEM- PLATE OF OLD QUADRANT
MYIWC	2	Eccentric, (Split) (For repair when driving wheels are not removed)	MYLSA	31	Reverse Lever Pivot
MYJAK	3	Eccentric Set Screw	MYLUS	32	Reverse Reach Rod Jaw
MYJEL	†*4	Eccentric Rod	MYLYT	33	Reverse Reach Rod Jaw Pin
MYJIM	†*5	Eccentric Strap	MYLBE	34	Reverse Shaft
MYJON	*	LINK (Complete)	MYLTX	35	Link Lifter Arm
MYJUP	6	Link (Heavy Section)	MYLZK	36	Reverse Shaft
MYJYR	7	" (Light Section)	MYMAN	37	Reverse Shaft Arm
MYJJA	8	" Block	MYMEP	38	Reverse Shaft Box
MYJBE	9	" Pin	MYMIR	39	Reverse Shaft Box
MYJDI	10	" End	MYMLO	40	Reverse Shaft Box Cap
MYJKY	11	" Bolt	MYMMU	41	Counterbalance Spring
MYKAL	12	" Saddle	MYMNY	42	Counterbalance Spring Rod
MYKEM	13	" Nut (Large)	MYMOS	43	Counterbalance Spring Washer
MYKIN	14	" Thimble	MYMRA	44	Rocker Arm
MYKMI	15	" Thimble	MYMSE	*45	Rocker Box
MYKNO	16	" Lifter	MYMUT	46	Rocker Box Cap
MYKOP	17	" Pin	MYNAP	*47	Valve Rod
MYKPU	18	" Thimble (Upper)	MYNER	48	Valve Rod Thimble
MYKRY	19	" Thimble (Lower)	MYNIS	49	Rocker Arm Pin
MYKUR	20	Eccentric Rod Pin (Including Taper Pin or Nut)	MYNLU	50	Valve Rod Key
MYKXE		REVERSE LEVER (Complete)	MYNMY	51	Valve Yoke (For Plain Slide Valve)
MYKKA	21	Reverse Lever Body	MYNNA	52	Valve Yoke (Balanced Valve)
MYKAB	22	" Handle	MYNOT	53	Plain Slide Valve
MYLAM	23	" Latch	MYNRE		BALANCED SLIDE VALVE (Complete)
MYLEN	24	" Gib	MYNSI	54	Balanced Slide Valve Body
MYLIP	25	" Strap	MYNUV	55	" Strip (Side)
MYLLI	26	" Spring	MYOAR	56	" (End)
MYLMO	27	" Rod	MYOES	57	" Spring (Long)
MYLNU	28	" Bushing (Upper)	MYOIT	58	" (Short)
MYLOR	29	" Bushing (Lower)			

\*Specify whether for **RIGHT** or **LEFT** side of locomotive.

†Specify whether **FRONT** or **BACK**.

Specify **BUILDER'S** locomotive **NUMBER** and **CODE WORD** with each order.





PLATE 35

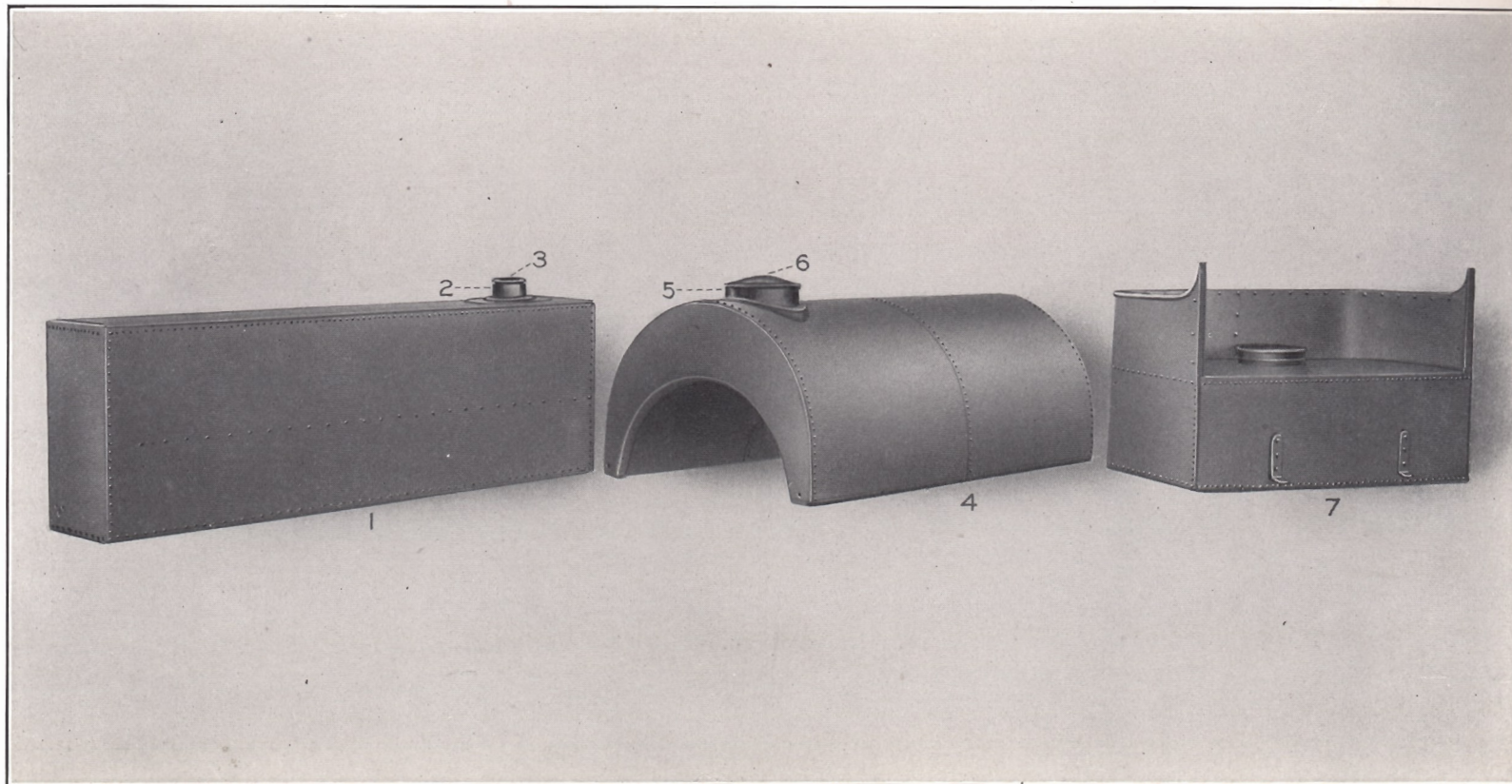



**WATER TANKS**

**PLATE 35**

CODE WORD	No.	NAME OF PART	CODE WORD	No.	NAME OF PART
MYOLY	1	Side Tank			
MYOMA	2	Side Tank Filling Hole Frame			
MYONE	3	Side Tank Filling Hole Lid			
MYOOV	4	Saddle Tank			
MYORI	5	Saddle Tank Filling Hole Frame			
MYOSO	6	Saddle Tank Filling Hole Lid			
MYOUW	7	Rear Tank, with Fuel Space Over Water			
MYOAS	8	Saddle Tank, Handhole Cover and Clamp			

Specify how tank should be painted.

Specify **BUILDER'S** locomotive **NUMBER** and **CODE WORD** with each order.



# INDEX

	PLATE	PAGE		PLATE	PAGE
Baffle Plate	23	57	Drawheads (Steel Tender Frame)	27	65
Balanced Slide Valve	34	79	Drawhook	5	17
Bell	22	55	Driving Box	8	23
Blower Pipe	23	57	Driving Box Equalizer	25	61
Blower Valve	1	9	Driving Box Shoes and Wedges	8	23
Blowoff Cock	1	9	Driving Wheels	8	23
Boiler Door	2	11	Drop Grate	10	27
Boiler Door Clamp	2	11	Dry Pipe	31	73
Boiler Flue	2	11	Eccentrics	34	79
Boiler Front	2	11	Eccentric Rods	34	79
Brake Cylinders and Details	3	13	Eccentric Straps	34	79
Brake Cylinder Drip Valves	3	13	Engineer's Brake Valve	3	13
Brake Details (Tender)	26	63	Engine Truck Details (Four-wheel)	32	75
Brake Hand Lever	3	13	Engine Truck Details (Two-wheel)	33	77
Brake Hangers	4	15	Engine Truck Equalizer	25	61
Brake Hanger Pivots	3	13	Exhaust Pipe	31	73
Brake Heads	4	15	Exhaust Nozzle	31	73
Brake Head Springs	4	15	Feed Water Valve or Tender Tank Valve	29	69
Brake Piston Rod Crosshead	3	13	Firedoor	2	11
Brake Quadrant	3	13	Firedoor Shade	2	11
Brake Shaft	3	13	Frames (Locomotive)	9	25
Brake Shaft Box	4	15	Frames (Steel Tender)	27	65
Brake Shoes	4	15	Frames (Wood Tender)	28	67
Brake Spreaders	4	15	Frame Pedestal Brace	9	25
Brake Valve—Engineer's	3	13	Gauge	1	9
Buffers	5	17	Gauge Cocks, Dripper and Details	1	9
Bumpers	5	17	Gauge Stand	1	9
Cab Lamp	1	9	Gauge Syphon	1	9
Cinder Hopper	2	11	Grates and Details	10	27
Counterbalance Spring Details	34	79	Grease Cups	11	29
Couplers	5	17	Guides	6	19
Crankpins	8	23	Guide Yoke	6	19
Cross Equalizer	25	61	Hand Brake Details	3	13
Crossheads and Details	6	19	Hand Hole Cover and Clamp	1	9
Cylinders (Locomotive) and Details	7	21	Hand Rail Columns	5	17
Cylinder Cock Rigging	7	21	Headlight Shelf	2	11
Cylinder Saddle	7	21	Helical Springs	25	61
Dead Grate	10	27	Horizontal Steam and Exhaust Pipes	31	73
Dome Cap	2	11	Injector Checks	1	9
Dome Casing	22	55	Injector—Metropolitan	12	31
Draw Bars	5	17	Injector—Monitor—Nos. 2 and 3	13	33
Drawheads	5	17	Injector—Monitor—Nos. 4 to 12	14	35



## INDEX—Continued

	PLATE	PAGE		PLATE	PAGE
Injector—Sellers—Class "M" 4.3.....	15	37	Smokebox Netting.....	23	57
Injector—Sellers—Class "M" Improved.....	16	39	Smoke Stacks.....	24	59
Injector—Sellers—Class "N" Improved.....	17	41	Springs and Spring Rigging (Locomotive).....	25	61
Injector Pipes.....	2	11	Staybolts.....	2	11
Injector Steam Valve.....	1	9	Steam Box.....	1	9
Injector Water Strainer.....	2	11	Steam Brake.....	3	13
Laird Guide.....	6	19	Steam Chest Details.....	7	21
Lift Pipe.....	23	57	Steam Chest Oiler and Details.....	7	21
Links and Details.....	34	79	Steam Gauge and Syphon.....	1	9
Lubricators (Detroit).....	19	45	Steam Gauge Cock.....	1	9
Lubricators (Nathan)—Old Style.....	18	43	Steam Pipes.....	31	73
Lubricator Steam Valve.....	1	9	Strainers (Injector Water).....	2	11
Main Rods.....	20	47	Tanks, Rear, Saddle and Side.....	35	81
Mud Plugs.....	1	9	Tee Heads.....	31	73
Oil Cups.....	11	29	Tender Brake (Steam and Hand).....	26	63
Parallel Rods.....	21	51	Tender Frame (Steel).....	27	65
Petticoat Pipe.....	23	57	Tender Frame (Wood).....	28	67
Piston and Rod (Locomotive Cylinders).....	6	19	Tender Frame Side Bearings.....	27	65
Piston Rod Gland.....	7	21	Tender Tank Details.....	29	69
Piston Rod Metallic Packing.....	7	21	Tender Tank Valve or Feed Water Valve.....	29	69
Poke Hole Details.....	2	11	Tender Tank Water Spigot.....	29	69
Pop Valve.....	1	9	Tender Truck and Details.....	30	71
Powell Grease Cups.....	11	29	Throttle Lever.....	31	73
Push Pole Pocket.....	5	17	Throttle Valve and Details.....	31	73
Radial Staybolt.....	2	11	Truck—Four-wheel—Engine.....	32	75
Rear Water Tank.....	35	81	Truck—Two-wheel—Engine.....	33	77
Reverse Lever Details.....	34	79	Uncoupling Shaft Columns.....	5	17
Reverse Shaft Counterbalance Spring.....	34	79	Valve Motion.....	34	79
Reverse Shaft Details.....	34	79	Valve Rod.....	34	79
Rocker Box and Arm.....	34	79	Valve Stem Gland.....	7	21
Rocker Grate.....	10	27	Valve Stem Metallic Packing.....	7	21
Rods—Main.....	20	47	Valve Yoke.....	34	79
Rods—Parallel.....	21	51	Washout Plug or Mud Plug.....	1	9
Saddle (Cylinder).....	7	21	Water Gauges.....	1	9
Saddle Tank.....	35	81	Water Gauge Glass.....	1	9
Safety Pop Valve.....	1	9	Water Pipes (Injector).....	2	11
Sandbox Details.....	22	55	Water Strainers (Injector).....	2	11
Shoes and Wedges.....	8	23	Water Tanks.....	35	81
Side Equalizer.....	25	61	Wedges—Driving Box.....	8	23
Side Tank.....	35	81	Wheels—Driving.....	8	23
Slide Valves.....	34	79	Whistle.....	1	9
Smokebox Door or Boiler Door.....	2	11			

